

*An Online PDH Course
brought to you by
CEDengineering.com*

Introduction to Electrical Codes, Drawings, Controls and Lighting Systems

Course No: E11-001

Credit: 11 PDH

S. Bobby Rauf, P.E., C.E.M., MBA



Continuing Education and Development, Inc.

P: (877) 322-5800
info@cedengineering.com

www.cedengineering.com

Preface

Many Non-engineering professionals as well as engineers who are not electrical engineers tend to have a phobia related to electrical engineering. One reason for this apprehensiveness about electrical engineering is due to the fact that electrical engineering is premised concepts, methods and mathematical techniques that are somewhat more abstract than those employed in other disciplines, such as civil, mechanical, environmental and industrial engineering. Yet, because of the prevalence and ubiquitous nature of the electrical equipment, appliances, and the role electricity plays in our daily lives, the non-electrical professionals find themselves interfacing with systems and dealing with matters that broach into the electrical realm. Therein rests the purpose and objective of this text.

This text is designed to serve as a resource for exploring and understanding basic electrical engineering concepts, principles, analytical strategies and mathematical strategies.

If your objective as a reader is limited to the acquisition of basic knowledge in electrical engineering, then the material in this text should suffice. If, however, the reader wishes to progress their electrical engineering knowledge to intermediate or advanced level, this text could serve as a useful platform.

As the adage goes, “a picture is worth a thousand words;” this text maximizes the utilization of diagram, graphs, pictures and flow charts to facilitate quick and effective comprehension of the concepts of electrical engineering.

In this text, the study of electrical engineering concepts, principles and analysis techniques is made relatively easy for the reader by inclusion of most of the reference data, in form of excerpts from different parts of the text, within the discussion of each case study, exercise and self-assessment problem solutions. This is in an effort to facilitate quick study and comprehension of the material without repetitive search for reference data in other parts of the text.

Due to the level of explanation and detail included for most electrical engineering concepts, principles, computational techniques and analyses

methods, this text is a tool for those engineers and non-engineers, who are not current on the subject of electrical engineering.

The solutions for end of the segment self-assessment problems are explained in just as much detail as the case studies and sample problem in the pertaining segments. This approach has been adopted so that this text can serve as an electrical engineering skill building resource for engineers of all disciplines. Since all segments and topics begin with the introduction of important fundamental concepts and principles, this text can serve as a “brush-up,” refresher or review tool for even electrical engineers whose current area of engineering specialty does not afford them the opportunity to keep their electrical engineering knowledge current.

In an effort to clarify some of the electrical engineering concepts effectively for energy engineers whose engineering education focus does not include electrical engineering, analogies are drawn from non-electrical engineering realms, on certain complex topics, to facilitate comprehension of the relatively abstract electrical engineering concepts and principles.

Each segment in this text concludes with a list of questions or problems, for self-assessment, skill building and knowledge affirmation purposes. The reader is encouraged to attempt these problems and questions. The answers and solutions, for the questions and problems, are included under Appendix A of this text.

Most engineers understand the role units play in definition and verification of the engineering concepts, principles, equations, and analytical techniques. Therefore, most electrical engineering concepts, principles and computational procedures covered in this text are punctuated with proper units. In addition, for the reader’s convenience, units for commonly used electrical engineering entities, and some conversion factors are listed under Appendix C.

Most electrical engineering concepts, principles, tables, graphs, and computational procedures covered in this text are premised on SI/Metric Units. However, US/Imperial Units are utilized where appropriate and conventional. When the problems or numerical analysis are based on only one of the two unit systems, the given data and the final results can – in most cases - be transformed into the desired unit system through the use of unit conversion factors in Appendix B.

Some of the Greek symbols, used in the realm of electrical engineering, are listed in Appendix C, for reference.

What readers can gain from this text:

- Better understanding of electrical engineering terms, concepts, principles, laws, analysis methods, solution strategies and computational techniques.
- Greater confidence in interactions with electrical engineering design engineers, electricians, controls engineers and electrical engineering experts.
- A number of skills necessary for succeeding in electrical engineering portion of various certification and licensure exams, i.e. CEM, Certified Energy Manager, FE, Fundamentals of Engineering (also known as EIT, or Engineer in Training), PE, Professional Engineering and many other trade certification tests.
- A better understanding of the electricity cost rate and electrical bill composition of electricity invoices of many large industrial and commercial power consumers.
- An introduction to certain commonly applied articles of the National Electrical Code.
- Better understanding of illumination principles and concepts, and an appreciation of efficient lighting/illumination design

An epistemic advice to the reader: if you don't understand some of the abstract concepts the first time, don't give up. Read it again! Such is the nature, intrigue and challenge of engineering, physics, science and other subjects that require thinking, reflection and rumination.

Table of Contents

Segment 1

National Electric Code[®], NFPA[®] 70 E and Electrical Standards

A brief introduction to the National Electric Code, limited introductory coverage of the NFPA 70E Arc Flash Regulations and an introduction to some common standards associations often referenced by electrical engineers and electricians. Example problems illustrating the application of NEC[®].

Segment 2

Electrical Drawings and PLC Relay Ladder Logic Program

Three common types of electrical drawings are discussed. These include a one-line power distribution schematic, a wiring diagram and electrical control drawings. The objective of this segment is to inculcate basic understanding of electrical symbols, electrical drawing conventions and electrical design strategy. In addition, the reader will be provided a brief introduction to PLC Relay Ladder Logic Programming.

Segment 3

Electrical Power Rate Schedules, Electrical Energy Cost Savings Opportunities

Electric power contract and billing schedule options available through most major power companies. Electrical power cost savings ideas in the industrial sector.

Segment 4

Illumination and Lighting System Design

Fundamental principles and concepts of illumination are introduced. Basic metrics associated with illumination and essentials of lighting system design are covered. Basic computational methods and illumination analysis associated with lighting system design are covered.

Appendix A

Solutions for end of segment self-assessment problems

Appendix B

Common units and unit conversion factors

Appendix C

Greek symbols commonly used in electrical engineering

Segment 1

National Electric Code, NFPA® 70 E and Electrical Standards

Introduction

The purpose of this segment is to merely introduce the reader to NEC® National Electrical Code. The coverage of the NEC® in this segment is not intended to provide the reader intermediate, advanced or expert level knowledge that is required and expected of a NEC® trained and practicing electrical Professional Engineer, specializing in power system design. Notwithstanding the foregoing clarification regarding the limited depth of NEC® knowledge provided in this segment, the nonelectrical engineer or the non-practicing electrical engineering reader will find that this segment on NEC® and electrical safety opens the door and allows the reader to appreciate the complexity and depth of the NEC®. And, most of all, if the nonelectrical reader of this segment finds themselves leading a group of electrical engineers and electricians in a “2:00 AM triage situation,” trying to troubleshoot and reinstate an important piece of equipment back into operation, the knowledge and familiarity they will gain in this segment should prepare them better to comprehend the code related jargon used by EE’s and electrical technicians.

The NEC® is revised every three years. At the time this text was authored, the 2011 revision was in effect. The reader is reminded that the objective of this text is not to provide precise code content and references at the time this text is read. Instead, the this text aims to give the reader *general* references of NEC® articles that have, *traditionally*, addressed the minimum requirements associated with equipment and appurtenances, i.e. conductors, conduits, raceways, fuses, breakers, grounding systems, etc.

Non-electrical engineering professionals often wonder if they should invest in the NEC® book. If so, what format and version would be most suitable? While the most appropriate answer to this question lies in the depth and extent of study intended, most non-electrical engineers might find the *NEC® handbook* more beneficial. The handbook version of the NEC® is replete with copious pictures, diagrams and illustrative example problems that aptly facilitate quicker comprehension of code and associated concepts.

In keeping with the approach utilized in the rest of this text, as we get introduced to certain commonly applied codes, we will take our knowledge

and comprehension to the next level through example problems, end of segment problems and the solutions at the back of the text.

NEC[®] Articles

Listed below are major NEC[®] articles that are introduced in this segment, followed by a few details that explain the significance of the articles. Later, in this segment, we will illustrate the significance of some of these NEC[®] articles through examples.

- Art. 90 - Introduction to NEC[®] & Outline.
- Art. 100 - Definitions, Including Enclosure Ratings
- Art. 110.6. - Conductor Sizes, AWG and Circular Mils.
- Article 110.16 - Arc Flash Regulations:
- Art. 110.26 - Clearances and Working Space Requirements.
- Art. 210 - Load Configurations and Voltages in Branch Circuits.
- Art. 210.9 - Autotransformers.
- Art 210.20 - Branch Circuit Ampacity Determination & Over current Protection.
- Art. 240 - Over current Protection
- Art. 240.50 – 240.101 - Circuit Breaker and Fuse Types
- Art. 250 - Grounding
- Art. 310 - Conductor Insulation Rating
- Art. 310.15 - Conductor Ampacity
- Art. 358 – 392 - Conduit and Cable Trays
- Art. 408.13 – 408.35 - Panel Boards

Art. 90 - Introduction to NEC[®] and Outline

Article 90 of the NEC[®] is a basic introduction to the intention of the codes. This article states the purpose of the code provision of uniform and practical means to safeguard people and equipment from electrical hazards. These safety guidelines are not meant to describe the most convenient or efficient installations and don't guarantee good service or allow for future expansion. The NEC[®] articles of code are designed to provide a standard for safety that protects against electrical shock and thermal effects, as well as dangerous over-currents, fault currents, overvoltage, etc. The NEC[®] comports, for the most part, with the principles for safety covered in Section 131 of the International Electrotechnical Commission Standard for electrical installations. International Electrotechnical Commission, or IEC, is the

world's leading organization that prepares and publishes ***International Standards*** for all electrical, electronic and related technologies.

Art. 100 – Definitions

Professionals who are not electrical engineers or electricians are likely to find this article on of the most useful articles. In that, this article contains definitions of terms that are essential in the understanding and interpretation of the code. As an introduction, a few of the terms described in Article 100 are listed and explained below.

Ampacity: Ampacity is defined as “The ***maximum*** current, in amperes, that a conductor can carry continuously under the conditions of use without exceeding its temperature rating.”

Note: Ampacity does vary depending on several factors. Appropriate NEC ® Tables and derating rules must be applied to determine the correct ampacity. See Article 310 for additional explanation.

Bonded (Bonding): Bonding is defined as equipment or objects “Connected to establish electrical continuity and conductivity.” In other words, bonding constitutes permanent joining of metallic parts to form an electrically conductive path that ensures electrical continuity and the capacity to conduct electrical current safely.

Note: This is not the same as grounding, but bonding jumpers are essential components of the bonding system, which is an essential component of the grounding system. Furthermore, note that the NEC does not authorize the use of the earth as a bonding jumper because the resistance of the earth is more than 100,000 times greater than that of a typical bonding jumper.

Branch Circuit: Branch circuit is defined as “The circuit conductors between the final overcurrent device protecting the circuit and the outlet(s).” As we will discuss and illustrate later, a branch circuit, as defined by the NEC ®, can be the entire circuit that lies between the overcurrent fuses and a motor load, in a typical motor branch circuit.

Continuous Load: A continuous load is defined by the NEC ® as "A load where the maximum current is expected to continue for 3 hours or more."

Note: The maximum running current referred to in this definition is exclusive of the *starting current*.

Feeder: A feeder is defined by the NEC ® as "All circuit conductors between the service equipment, the source of a separately derived system, or other power supply source and the final branch-circuit overcurrent device."

Ground: A ground is defined by the NEC ® as simply "The earth." On the other hand, the term **Grounded (Grounding)** is defined as "Connected (Connecting) to ground or to a conductive body that extends the ground connection."

Note: Simply driving an electrode into the earth does not constitute grounding a circuit. The ground must be made with the source or supply in mind, as the flow of electrons – or current – always tries to *return* to the source.

In Sight From (Within Sight From, Within Sight): The NEC ® defines this as "Where this Code specifies that one equipment shall be 'in sight from,' 'within sight from,' or within sight of,' and so forth, another equipment, the specified equipment is to be visible and not more than 15 m (50 ft) distant from the other." In other words, lockable disconnecting means must be provided in sight of the load, unless the specific installation meets the criteria stated under article 430.102 (B) (2) (a) or (b).

Labeled: The NEC ® defines this as "Labeled. Equipment or materials to which has been attached a label...acceptable to the authority having jurisdiction and concerned with product evaluation,...."

Note: The reader is advised to read the entire original definition in order to attain full understanding of this term.

Neutral Conductor: The NEC ® defines this as "The conductor connected to the neutral point of the system that is intended to carry current under normal circumstances.

Overcurrent: The NEC ® defines overcurrent as "Any current in excess of the rated current of equipment or the ampacity of a conductor. It may result from overload, short circuit or ground fault."

Overload: The NEC ® defines overload as "Operation of equipment in excess of normal, full-load rating, or of a conductor in excess of rated ampacity that, when it persists for a sufficient length of time, would cause damage or dangerous overheating. A fault, such as short circuit or ground fault, is not an overload."

Raceway: The NEC ® defines raceway as "An enclosed channel of metal or nonmetallic materials designed expressly for holding wires, cables, or bus-bars.

Note: The reader is advised to read the entire original definition in order to attain full understanding of this term.

Short-Circuit Current Rating: The NEC ® defines this term as "The prospective symmetrical fault current at a nominal voltage to which an apparatus or system is able to be connected without sustaining damage exceeding defined acceptable criteria."

Voltage, Nominal: The NEC ® defines nominal voltage as "A nominal value assigned to a circuit or system for the purpose of conveniently designating its voltage class (e.g., 120/240 volts, 480/277 volts, 600 volts). The actual voltage at which a circuit operates can vary from the nominal within a range that permits satisfactory operation of equipment."

Art. 110.6. - Conductor Sizes, AWG and Circular Mils.

Overall Article 110 lays out the requirements for electrical installations. Article 110.6, specifically, addresses conductor sizes. This article clarifies the fact that the conductor sizes are expressed in AWG, American Wire Gage or in circular mils. For copper, aluminum or copper clad aluminum conductors up to size 4/0 AWG, the code identifies the conductor sizes in AWG. Conductors larger than 4/0 AWG are sized in circular mils, beginning with 250,000 mils; formerly referred to as 250 MCM. Where first "M" stands for 1000. The unit *kcmil* was adopted 1990. Therefore, the more contemporary identification of a 250,000 mil conductor would be 250 *kcmil*. Note: 1 mil is equal to 1/1000th of an inch.

Article 110.16 – Arc-Flash Hazard Warning

This article addresses stipulation associated with potential hazard of arc-flash incidents initiated by electrical faults. The essence of the *Code*, in this article is that switchboards, panel-boards, industrial control panels, meter socket enclosures, and motor control centers in other than dwelling units, which are likely to require examination, adjustment, servicing, or maintenance while energized, shall be field marked to warn qualified persons of potential electric arc flash hazards. The marking or label shall be located so as to be clearly visible to qualified persons before examination, adjustment, servicing, or maintenance of the equipment. An example of a label generated as a result of arc flash hazard analysis is shown in Figure 1.1. Look for additional discussion on the topic of arc flash later in this segment.

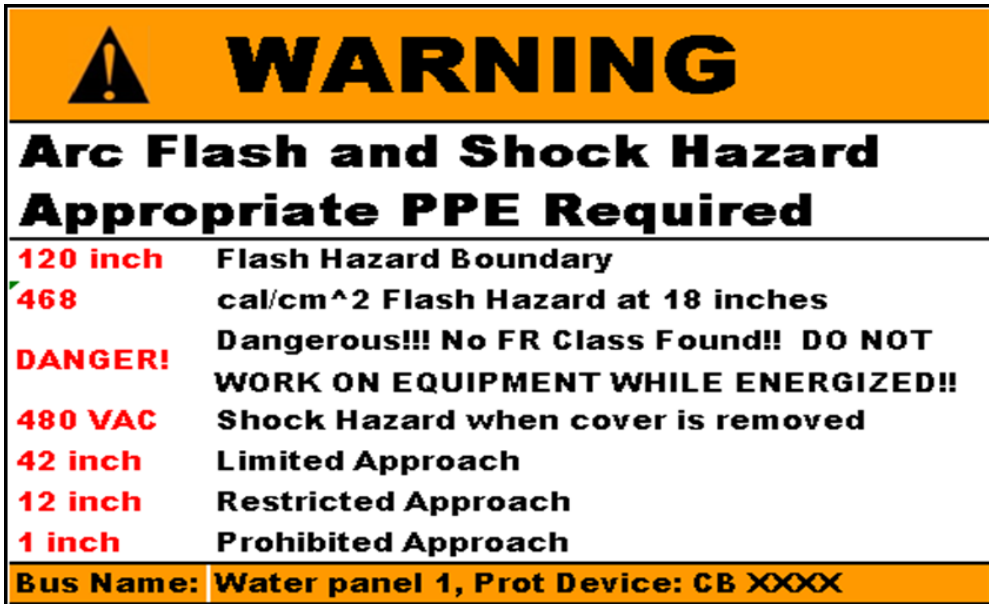

Figure 1.1: Arc-flash hazard label, produced through arc-flash hazard analysis.

Art. 110.26 - Clearances and Working Space Requirements

This article of the Code states: “Access and working space shall be provided and maintained about all electrical equipment to permit ready and safe operation and maintenance of such equipment.” The essence of this article is that one cannot install electrical equipment in just *any* available

physical space. Equipment must be installed such that it can be accessed, safely, at all times by maintenance personal.

Art. 210 - Branch Circuits

This article applies to branch circuits that supply power to motor and non-motor loads. Article 430 must be consulted for situations where branch circuits feed motors only. The NEC ® handbook contains myriad illustrations of different types of branch circuits and associated code requirements.

Art. 210.9 – Circuits Derived from Autotransformers

This article stipulates: “Branch circuits shall not be derived from autotransformers unless the circuit supplied has a grounded conductor that is electrically connected to a grounded conductor of the system supplying the autotransformer.” In addition to explanation of this code, the handbook shows circuit diagrams of autotransformers connected in various configurations.

Art 210.20 - Overcurrent Protection

According to 210.20, an overcurrent device that supplies continuous and non-continuous loads must have a rating that is not less than the sum of 100 percent of the non-continuous load plus 125 percent of the continuous load, calculated in accordance with Article 210. Because grounded/neutral conductors are generally not connected to the terminals of an overcurrent protective device, this requirement for sizing conductors subject to continuous loads does not apply.

Art. 240 - Overcurrent Protection

This article of the *Code* provides the requirements for selecting and installing overcurrent protection devices (OCPDs). On one hand an OCPD protects a circuit by opening the circuit when current reaches a value that would cause an excessive temperature rise in the conductors. If one were to apply the rising water analogy, current rises like water in a tank, and at a certain level, the OCPD shuts off the faucet. On the other hand, an OCPD protects equipment by opening the circuit when it detects a short circuit or ground fault. All electrical equipment must have a short-circuit current rating that permits the OCPDs to clear short circuits or ground faults without a catastrophic failure.

Art. 240.50 – 240.101 - Circuit Breaker and Fuse Types

Articles, ranging from Art. 240.50 – 240.101, address requirements associated with selection, specification and installation of various overcurrent protection devices such as circuit breakers and fuses. Once again, in addition to explanation of the code, the handbook shows diagrams and pictures of various types of fuses and a breaker tripping unit.

Art. 250 – Grounding and Bonding

Overall, this article addresses general requirements for grounding and bonding of electrical installations, types and sizes of grounding and bonding equipment, methods of grounding and bonding, and situations when guards, isolation, or insulation may be substituted for grounding.

Art. 310 – Conductors and General Wiring

This NEC ® article addresses general requirements for conductors, their types, insulations, markings, mechanical strengths and ampacity ratings. Table 310.15 lists ampacities of various conductors and is, possibly, the most frequently used page in the *Code*. See additional discussion below on conductor ampacity.

Art. 358 – Electrical Metallic Tubing: Type EMT

This article of the *Code* addresses the application, installation and construction specifications for electrical metallic tubing (conduit) and associated tubing.

Art. 408 - Switchboards and Panelboards

This article of the *Code* covers switchboards and panelboards associated with equipment operating at 600 volts or less.

Ampacity of conductors – Table 310-15

In order to provide a measure of familiarity with the most frequently used section of the NFPA, NEC, National Electric Code, an older version of NEC Table 310-15 has been included under Tables 1.1 and 9.2. Closer examination of this table shows that the ampacities of various conductors are listed under two separate sections. The left section represents copper conductors and the right section represents the aluminum or copper clad aluminum conductors. These two sections are divided further into three columns each. These three columns list the ampacities of various

commercially available conductors under three temperature categories: 60°C (140°F), 75°C(167°F) and 90°C(194°F). Note that these three separate temperature columns lump different types of commercially available insulations. The temperature and insulation columns are selected in accordance with specific application, environment and ambient temperature. The bottom section of Table 1.2 represents the conductor ***ampacity correction factors*** based on the ambient temperatures above or below 30°C.

The methods associated with the application of NEC[®] articles are illustrated through example problems listed below. However, the NEC[®] articles cited are subject to change, without notice, due to periodic code revisions and were meant to be valid at the time of development of these problems. Therefore, these NEC[®] article references may not be current and should not be used for actual practice of electrical engineering design. Instead, reader should refer to the most current NEC[®] articles in their practice of engineering.

Table 310.15(B)(2)(a) Adjustment Factors for More Than Three Current-Carrying Conductors in a Raceway or Cable						
Size AWG or kcmil	Temperature Rating of Conductor	COPPER			ALUMINUM OR COPPER-CLAD ALUMINUM	
		Types RHW, THHW, THW, THWN, XHHW, USE, ZW	Types THW, UF	Types TBS, SA, SIS, FEP, FEPB, MI, RHH, RHW-2, THHN, THHW, THW-2, THWN-2, USE-2, XHH, XHHW, XHHW-2, ZW-2	Types RHW, THHW, THW, THWN, XHHW, USE	Types TBS, SA, SIS, THHN, THHW, THW-2, THWN-2, RHH, RHW-2, USE-2, XHH, XHHW, XHHW-2, ZW-2
	60°C (140°F)	75°C (167°F)	90°C (194°F)	60°C (140°F)	75°C (167°F)	90°C (194°F)
18	-	-	14	-	-	-
16	-	-	18	-	-	-
14*	20	20	25	-	-	-
12*	25	25	30	20	20	25
10*	30	35	40	25	30	35
8	40	50	55	30	40	45
6	55	65	75	40	50	60
4	70	85	95	55	65	75
3	5	100	110	65	75	85
2	95	115	130	75	90	100
1	110	130	150	85	100	115
1/0	125	150	170	100	120	135
2/0	145	175	195	115	135	150
3/0	165	200	225	130	155	175
4/0	195	230	260	150	180	205
250	215	255	290	170	205	230
300	240	285	320	190	230	255
350	260	310	350	210	250	280

Table 1.1: NEC ® Ampacity table superseded by current NEC Table 310.15(B)(16). Included for general illustration purposes, only. Courtesy, NEC, NFPA.

Table 310.15(B)(2)(a) Adjustment Factors for More Than Three Current-Carrying Conductors in a Raceway or Cable						
Size AWG or kcmil	Temperature Rating of Conductor					
	60°C (140°F)	75°C (167°F)	90°C (194°F)	60°C (140°F)	75°C (167°F)	90°C (194°F)
Size AWG or kcmil	Types TW, UF	Types RHW, THHW, THW, THWN, XHHW, USE, ZW	Types TBS, SA, SIS, FEP, FEPP, MI, RHH, RHW-2, THHN, THHW, THW-2, THWN-2, USE-2, XHH, XHHW, XHHW-2, ZW-2	Types TW, UF	Types RHW, THHW, THW, THWN, XHHW, USE	Types TBS, SA, SIS, THHN, THHW, THW-2, THWN-2, RHH, RHW-2, USE-2, XHH, XHHW, XHHW-2, ZW-2
	COPPER			ALUMINUM OR COPPER-CLAD ALUMINUM		
CORRECTION FACTORS						
Ambient Temp. (°C)	For ambient temperatures other than 30°C (86°F), multiply the allowable ampacities shown above by the appropriate factor shown below.					
21-25	1.08	1.05	1.04	1.08	1.05	1.04
26-30	1	1	1	1	1	1
31-35	0.91	0.94	0.96	0.91	0.94	0.96
36-40	0.82	0.88	0.91	0.82	0.88	0.91
41-45	0.71	0.82	0.87	0.71	0.82	0.87
46-50	0.58	0.75	0.82	0.58	0.75	0.82
51-55	0.41	0.67	0.76	0.41	0.67	0.76
56-60	-	0.58	0.71	-	0.58	0.71
61-70	-	0.33	0.58	-	0.33	0.58
71-80	-	-	0.41	-	-	0.41
* Small Conductors. Unless specifically permitted in 240.4(E) through (G), the overcurrent protection shall not exceed 15 amperes for 14 AWG, 20 amperes for 12 AWG, and and copper-clad aluminum after any correction factors for ambient temperature and number of conductors have been applied.						

Table 1.2: NEC ® Ampacity table superseded by current NEC Table 310.15(B)(16). Included for general illustration purposes, only. Courtesy, NEC, NFPA.

Example 1.1

Over current Protection:

Applicable Code/Codes: Articles 210.19 (A) (1), 210.20 (A) and 310.15. Tables 310.15(B)(2)(a) and 310.15(B)(16).

The branch circuit in the exhibit below consists of two (2) 8 amp continuous loads. Over current protection in the branch circuit is provided through a 20 amp circuit breaker. (a) Verify the size/specifications of the circuit breaker and the 12 AWG conductor, assuming conductor temperature at 60°C (140°F) or less. (b) If the ambient temperature were to rise to 50°C, how would the conductor size be impacted?

Conductor and OCPD, Over Current Protection Device, verification:

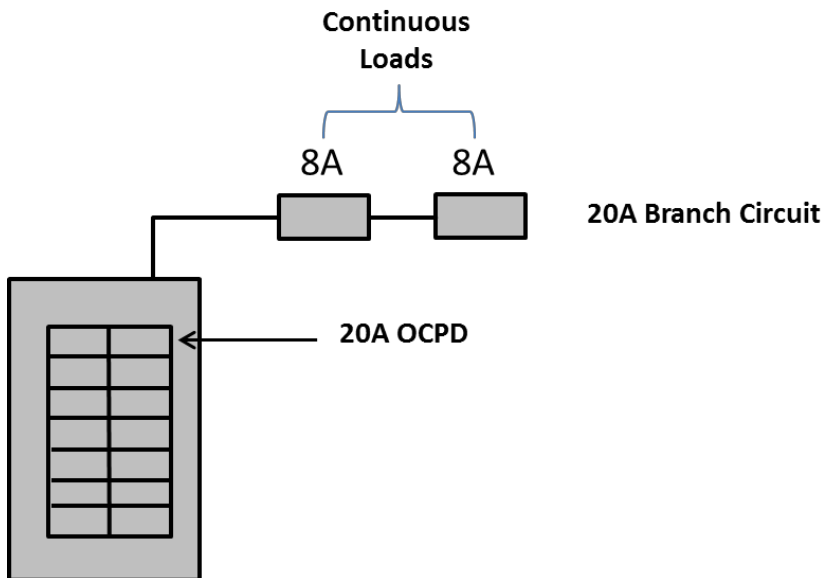

Solution:

In accordance with article 210.20 (A), which stipulates:

“Branch-circuit conductors and equipment shall be protected by overcurrent protective devices that have a rating or setting that complies with 210.20(A) through (D).

(A) Continuous and Non-continuous Loads. Where a branch circuit supplies continuous loads or any combination of continuous and non-

continuous loads, the rating of the overcurrent device shall not be less than the non-continuous load plus 125 percent of the continuous load.” NEC® 2011.

The over current protection should be rated = $1.25 \times \text{Continuous Load}$
= $1.25 \times (8 \times 2A) = 20 \text{ amps}$.

∴ The 20 amp circuit breaker as an over current protection device is adequate for the given branch circuit.

In accordance with article 210.19 (A) (1): “Branch circuit conductors shall have an ampacity not less than maximum load to be served....(and) shall have an allowable ampacity not less than the non-continuous load plus 125% of the continuous load.

∴ The conductor ampacity for the given branch circuit
= $1.25 \times \text{Continuous Load} + 1.00 \times \text{Non-Continuous Load}$
= $1.25 \times (16A) + 1.00 \times (0) = 20 \text{ amps}$.

According to Table 310.15(B) (16), for 60°C operation, with Type TW or UF insulation, AWG 12 conductor carries an allowable ampacity of 20 amps for conductors that are insulated, rated for 0 – 2000 volt operation, in situations with no more than three (3) current carrying conductors in raceway, cable earth (directly buried); under ambient temperature (not exceeding) 30°C (85°F); with no required/applicable derating.

∴ Selection of AWG 12 would be adequate for this scenario.

(b) Ambient Temperature Rise and Conductor size:

According to Article 310.15, Tables 310.15(B)(2)(A) and 310.15(B)(16), when ambient deviates from 30°C to 50°C, a derating multiplier of 0.58 must be applied to adjust the ampacity of the conductor.

∴ The adjusted or derated ampacity of AWG #12 conductor, in this case, would be:

$$= 0.58 \times 20 \text{ amps} = 11.6 \text{ amps}$$

Since the derated ampacity of AWG #12, for this application, falls below the 20 amp capacity mandated by 210.19 (A) (1), AWG #12 would no longer be adequate. Therefore, AWG #10, which is the next size above AWG#12, must be considered. According to Table 310.15(B)(16), for 60°C operation, with Type TW or UF insulation, AWG#10 conductor carries an allowable ampacity of 30 amps. Then, if the 50°C adjustment rating of 0.58 is applied to 30 amp ampacity of AWG #10, the derated ampacity would be:

$$= 0.58 \times 30 \text{ amps} = 17.4 \text{ amps}$$

Since the 17.4 amp derated ampacity of AWG #10 still fall short of the 20 amp requirement, it would **not** meet the code. So the next larger size conductor, AWG #8, with an ampacity of 40 amps should be considered.

If the 50°C adjustment rating of 0.58 is applied to the 40 amp ampacity of an AWG # 8 conductor, the derated ampacity would be:

$$= 0.58 \times 40 \text{ amps} = 23.2 \text{ amps}$$

The 23.2 amp derated ampacity of AWG #10 exceeds the 20 amp requirement, therefore, it would meet the code.

Example 1.2

Over current Protection and Minimum Conductor Size

Applicable Code/Codes: 210.20 (A), 240.6(A), 210.19 (A) (1), 310.15 and Table 310.15 (B) (16).

Determine the size of over current protection device and the minimum conductor size for the following scenario assuming that no derating applies:

- Four (4) current carrying copper conductors in a raceway.
- Operating temperature and OCPD, Over current Protective Device, terminal rating: 60°C
- Insulation: THWN
- Load: (calculated) 26 amps, continuous.

Solution:

Size of the OCPD:

In accordance with article 210.20 (A), over current protection should be rated
 $= 1.25 \times \text{Continuous Load} = 1.25 \times (26\text{A}) = 32.5 \text{ amps.}$

According to article 240.6(A), standard ampere rating above 30 amp is 35 amp.

∴ The minimum standard size or rating of the **OCPD device should be 35 amps.**

Minimum Conductor Size:

In accordance with article 210.19 (A) (1), the branch circuit conductors shall have an ampacity not less than maximum load to be served.....(and) shall have an allowable ampacity not less than the non-continuous load plus 125% of the continuous load.

∴ The conductor ampacity for the given branch circuit $= 1.25 \times \text{Continuous Load} + 1.00 \times \text{Non-Continuous Load} = 1.25 \times (26\text{A}) + 1.00 \times (0) = 32.5 \text{ amps.}$ **Select AWG 8 which has an ampacity of 40 amps.**

Example 1.3

Appliance Load – Dwelling Unit(s):

Applicable Code/Codes: 220.53

Determine the feeder capacity needed for a 120/240 VAC, fastened-in-place, appliance load in a dwelling unit for the following appliances:

- Water Heater, Rated: 4000 W, 240 V; Load: 4000 VA (PF = 1)
- Kitchen Disposal, Rated: 0.5 hp, 120 V; Load: 1176 VA (PF & Eff. <<100%)
- Dishwasher, Rated: 1200 W, 120 V; Load: 1200 VA (PF = 1)
- Furnace Motor, Rated: 0.25 hp, 120 V; Load: 696 VA (PF & Eff. <<100%)
- Attic Fan Motor, Rated: 0.25 hp, 120 V; Load: 696 VA (PF & Eff. <<100%)

- Water Heater, Rated: 0.5 hp, 120 V; Load: 1176 VA (PF = 1)

Solution:

$$\begin{aligned} \text{Total Load} &= 4000 \text{ VA} + 1176 \text{ VA} + 1200 \text{ VA} + 696 \text{ VA} + 696 \text{ VA} + 1176 \\ &\text{VA} \\ &= 8944 \text{ VA} \end{aligned}$$

Since the total load consists of more than four (4) appliances, according to article 220.53, a demand factor of 75 % is permissible.

$$\begin{aligned} \therefore \text{The size of the service and feeder conductors may be based on net load:} \\ &= 0.75 \times 8,944 \text{ VA} \\ &= \mathbf{6,708 \text{ VA}} \end{aligned}$$

Example 1.4

Outlets in Dwelling Unit(s):

A 120 V dwelling branch circuit supplies four outlets, one of which has four receptacles. What is the total volt-ampere load?

Solution:

According to article 220.14(I), a single outlet is counted as a 180 VA load. So the three outlets, out of the four would constitute a load of:

$$= (3) (180 \text{ VA}) = 540 \text{ VA}$$

Each of the receptacles, in the fourth outlet - with four receptacles - according to article 220.14(I), would constitute a load of 90 VA. Therefore, the total load contribution from the four receptacles would be:

$$\begin{aligned} &= (\text{numbers of receptacles}) (90 \text{ VA/receptacle}) \\ &= (4) (90 \text{ VA}) = 360 \text{ VA} \end{aligned}$$

$$\therefore \text{The total load is } = 540 \text{ VA} + 360 \text{ VA} = \mathbf{900 \text{ VA}}$$

Arc Flash

While some background information on the subject of arc flash is presented under Article 110.16 of the NEC ®, the National Electric Code, NEC ®, is not a core source for information on arc flash regulations. The subject of arc flash is comprehensively addressed by **NFPA 70 E**. The latest version of NFPA 70 E was released in 2012. In the recent years, NFPA 70 E,

similar to the NEC ®, has been revised every three years. Like the NEC ®, NFPA 70 E is available in print, on-line and in other electronic format, i.e. CD. Arc flash is being introduced in this text primarily due to the importance and gravity of arc flash hazard in the electrical work environment. The introduction of arc flash in this text is at the basic level and **does not** enable the reader to adequately practice arc flash safety.

Basic facts related to arc flash are listed below:

- Arc flash is the result of a rapid release of energy due to an arcing fault between a **phase bus bar and another phase bus bar, neutral or a ground**.
- Arc faults are typically limited to systems with the bus voltage is in **excess of 120 volts**.
- An arc fault is similar to the arc obtained during **electric welding**.
- The massive energy discharged during an arc fault phenomenon has the **capacity to burn bus bars, vaporize the copper and cause an explosive volumetric increase**.
- An arc blast is estimated to cause explosive expansion of gas or air to magnitudes exceeding **40,000 to 1**.
- The essence of relative magnitude or intensity of arc flash can be understood and appreciated through Eq. 1.1:

$$\text{Arc Flash Energy, or Incident Energy} = (V).(I).(t) \quad \text{Eq. 1.1}$$

In Eq. 1.1, the arc flash energy, or incident energy, is the energy released by an arc flash fault. This energy can be measured in kWh, Watt – sec, Joules, calories, BTU's, therms, etc. In arc flash analysis, arc flash classifications and arc flash PPE (Personal Protective Equipment) ratings, arc flash energy “intensity” term “Calories/cm²” is commonly used. In Eq. 1.1, “V” is the rms (root mean square) voltage, “i” is the rms (root mean square) fault current and “t” is the duration of the arc fault, in seconds. The arc fault current magnitude, typically, ranges in 1,000's of

amps and the fault duration is typically in milliseconds. As obvious, this equation stipulates that arc fault energy is directly proportional to the voltage, current and fault duration. Note that, over the time span or duration of the fault, the voltage change is negligible in comparison with the order of magnitude rise in the current level. Therefore, mostly, the magnitude of the fault current is responsible for the enormity of the arc flash energy.

- Temperature in ARC Plasma is approx. 5,000°F.
- There are approximately 5 – 10 arc flash incidents (explosions) recorded per day, in the US.
- Average medical cost associated with remediation is estimated to exceed \$1.5 Million per incident. Total cost, including litigation, is estimated to be \$8 – 10 Million per incident.
- OSHA, Occupational Safety and Health Administration, carries the Arc Flash regulation enforcement responsibility.

Compliance with OSHA involves adherence to a six-point plan:

- A facility must provide, and be able to demonstrate, a safety program with defined responsibilities.
- Calculations for the degree of arc flash hazard, at electrical equipment rated or operating at 120V, or greater.
- Warning labels on equipment. Note that the labels are provided by the equipment owners, not the manufacturers.
- Provision of proper personal protective equipment (PPE) for workers, as prescribed by proper arc flash hazard analysis.
- Initial training, and subsequent refresher training, for workers on:
 - The hazards of arc flash
 - The proper interpretation of arc flash hazard labels
 - Proper use of arc flash PPE and voltage rated tools and gloves.

Physical and thermal background of arc flash

This section is devoted to the exploration of the physical, chemical and thermal aspects of arc flash phenomena. This discussion is intended to enhance technicians' and engineers' appreciation of the reasoning behind arc flash hazard analysis requirements and the need for arc flash PPE. Pictures from two different arc flash simulations are depicted in figures 1.2 and 1.3. The picture in Figure 1.2 depicts a simulated arc-flash incident, conducted at 250V, 13.1 KA (13,100 amps). The energy intensity for this simulated 13,100 amp fault is estimated to be 1.48 Cal/cm². The picture in Figure 1.3 depicts a simulated arc-flash incident, conducted at 250V, 44 KA (44,000 amps). The energy intensity for this simulated 44,000 amp fault is estimated to be 8.48 Cal/cm², almost *six times the fault energy* released by the lower current fault. Note that the voltage in both simulations was 250 V. This observation supports the directly proportional relationship between fault current and the arc flash fault energy as stipulated in the fault energy equation, Eq. 1.1.



Figure 1.2: Simulated arc-flash incident, conducted at 250V, 13.1 KA (13,100 amps). Energy intensity: 1.48 Cal/cm².

Some of the hazards associated with an arc flash incident are evident from pictures in figures 1.2 and 1.3. These hazards are as follows:

- **Extreme Heat** – Energy contained in explosive arc flash events raises the temperature thousands of degrees; to the extent that it not only melts copper components but vaporizes them. Immense heat energy contained in vaporized copper can burn through or ignite regular work clothes. In addition, human skin coming in contact with vapors at such high temperatures would result in third degree burns. Temperature in ARC Plasma is approx. 5,000°F. Proper PPE, including hood, balaclava, arc rated coveralls and jacket can provide a measure of protection against the radiated heat and the heat contained in the vapors. See the PPE section below.
- **Brilliant Flash** – Without adequate tinting and shielding, the intense light that accompanies the release of immense explosive energy can result in retina damage and can cause blindness.
- **High UV Emission** – The ultra-violet light that accompanies arc flash events can damage human epithelial (skin) layer. Once again, proper arc rated clothing can provide a measure of protection.
- **Shock Wave** – Vaporization of copper accompanies 67,000 times 1 expansion of air and gases. The intense instantaneous expansion of gases is tantamount to explosion of ordinance and results in a shock wave. The shock wave can launch workers off their feet resulting in broken limbs and bones. The explosive energy laden shock waves have the capacity to subject anterior of a human body to immense pressure, potentially, fracturing ribs, puncturing and collapsing lungs. Best practices associated with *safe posture* can provide a measure of protection against effect of a shock wave.
- **Concussion (Noise)** – Due to the fact that expanding vaporized copper is an explosive event, it generates a loud report. This is the reason why hearing protection is required by NFPA 70 E.
- **Projectiles** – As visible in figures 1.2 and 1.3, energy contained in arc flash events projects components outward in solid or molten form. Note the bright streaks in the picture of the simulated arc faults. The projectiles launched in arc flash events can result in shrapnel injuries.

- **Electrical Shock** – The explosion associated with arc flash events dislodges components, insulation and conductors; thus, exposing personnel, in close proximity, to live energized components. This exposure can result in electrical shock hazard.



Figure 1.3: Simulated arc-flash incident, conducted at 250V, 44 KA (44,000 amps). Energy intensity: 8.48 Cal/cm².

Arc Flash PPE

Having gained some appreciation of the hazards, and causes thereof, associated with arc flash events, let's consider some of the PPE required by NFPA 70E. The PPE introduced here pertains to the lowest and highest arc flash hazard classifications. These classifications are Class or Category 0 and Class or Category 4. Other classifications are not discussed in this text. Arc flash hazard PPE for Class 0 and Class 4, in accordance with NFPA 70E are as follows:

Protective Clothing and PPE, Hazard/Risk Category or Class 0, for 0 to 1.2 cal/cm²:

- Protective clothing, non-melting or untreated made from natural fiber (i.e., untreated cotton, wool, rayon, or silk, or blends of these materials) with a fabric weight of at least 4.5 oz/yd²
- Long sleeve shirt
- Long pants
- Safety glasses or safety goggles
- Hearing protection (i.e. ear plugs)

- Heavy duty leather gloves

Protective Clothing and PPE, Hazard/Risk Category or Class 4, 25 to 40 cal/cm²:

- Arc-rated clothing selected so that the system arc rating meets the required minimum arc rating of 40 cal/cm²
- Arc-rated long-sleeve shirt
- Arc-rated pants
- Arc-rated coverall
- Arc-rated arc flash suit jacket
- Arc-rated arc flash suit pants
- Arc-rated arc flash suit hood
- Arc-rated gloves
- Arc-rated jacket, parka, rainwear, or hard hat liner
- Hard hat
- Safety glasses or safety goggles
- Hearing protection (i.e. ear plugs)
- Leather work shoes

An example of a PPE system that conforms to the NFPA 70 E Class 4 hazard is depicted in Figure 1.4 below:



Figure 1.4: Example of NFPA 70 E Class 4 PPE

PPE requirement can be assessed on the basis of NFPA 70 E default table or through arc flash hazard analysis. The labels depicted in figures 1.5 and 16 are a product of arc flash hazard analysis. The label shown in Figure 1.5 represents a Class 0 equipment scenario, where potential arc flash hazard energy is determined to be less than 1.2 cal/cm².

 WARNING	
Arc Flash and Shock Hazard	
Appropriate PPE Required	
48 inch	Flash Hazard Boundary
MAX OF 1.2	cal/cm² Flash Hazard at 18 inches
Class 0	VR Gloves-Tools, Proper Clothes W/ Safety Glasses
UP TO 240 VAC	Shock Hazard when cover is removed
42 inch	Limited Approach
Avoid Contact	Restricted Approach
Avoid Contact	Prohibited Approach

Figure 1.5: Example of a Classification “0” label generated as a result of an arc flash hazard analysis, based on NFPA 70 E, 2009.

On the other hand, the label shown in Figure 1.6 pertains to electrical equipment that has the potential for drawing enough fault current to exceed the energy intensity level of 40 cal/cm². When fault energy intensity of 40 cal/cm² is exceeded, as stipulated on the label in Figure 1.6, work on energized equipment is not permitted.

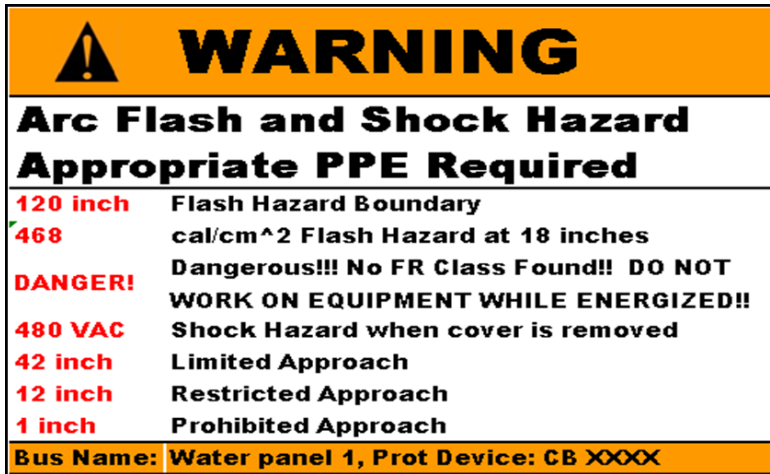

Figure 1.6: Example of a label pertaining to higher than 40 cal/cm² arc flash hazard, based on NFPA 70 E, 2009.

Electrical safety certifications

Certifications and certification labels on electrical equipment are intended to provide the end user, installer or integrator a measure of assurance that the labeled equipment is safe when applied or used as prescribed by the manufacturer. The certification labels can be found at the bottom, rear or sides of non-custom, off-the-shelf, standard electrical equipment. See Figure 1.7.



(a)

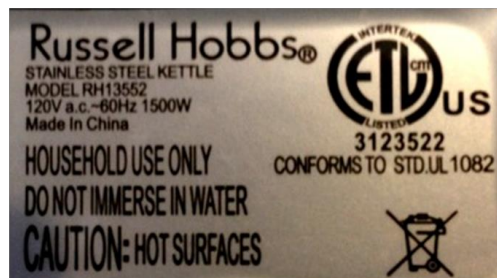

(a)

Figure 1.7: Examples of a safety certification labels – ETL and UL Listings.

Various certifications exist in different parts of the world. A few, more prominent ones, are mentioned in this text as matter of introduction. These certifications are listed below:

- **UL[®]**, Underwriters Laboratories, United States. UL[®], tests equipment to be certified for safety, either at laboratories owned and operated by UL or at laboratories owned and operated by its sub-contractors, such as **ETL^{CM}**.
- **ETL^{CM}**, Intertek Listing. The ETL Listed Mark is proof of product compliance (electrical, gas and other safety standards) to North American safety standards. Following authorities having jurisdiction in 50 states and Canada accept the ETL Listed Mark as proof of product safety: UL, ANSI (American National Standards Institute), CSA (CSA Group), ASTM (formerly known as: American Society for Testing and Materials), NFPA (National Fire Protection Agency), and NOM (Norma Official Mexicana).
- **NOM Mark:** (Norma Official Mexicana) NOM is a mark of product safety approval for virtually any type of product exported into Mexico.
- **ULC**, Underwriters Laboratories of Canada.
- **IEC**, International Electrotechnical Commission. The IEC plays an important role in developing and distributing electrical standards. IEC was instrumental in developing and distributing standards for units of measurement, particularly the gauss, hertz and weber. IEC first proposed a system of standards, the Giorgi System, which ultimately became the SI, or *Système International d'unités* (in English, the International System of Units).
- **IP Rating:** IP rating stands for *International Protection* rating. Sometimes interpreted as *Ingress Protection* rating, the IP rating consists of the letters **IP** followed by two digits and an optional letter. As defined in IEC 60529 60529, it classifies the degrees of protection provided against the intrusion of solid objects (including body parts like hands and fingers), dust, accidental contact, and water in electrical

enclosures. See **Table 1.2** for correspondence between the American **NEMA[®] ratings** and their counterparts in the **IP** realm. Also see Example 1.5 for illustration of enclosure ratings application.

- **CE Certification:** The CE Mark stands for *Conformité Européenne*, a French term that can be literally translated into English as *European Conformity*.
- **Safety Compliance Statement** from the manufacturer, engineering firm, general contractor, turn-key installer or system integrator is often required on custom engineered systems or equipment. This requirement must be clarified and agreed upon - at the quotation/bidding phase of the project - between the project manager, end-user/customer, plant safety manager, engineering firm, general contractor, turn-key installer and the system integrator (if applicable). Absence of such documented agreement on Safety Compliance Statement requirement, at the very outset of a custom engineered project, can result in system commissioning and start-up delays, in addition to penalties, unforeseen costs, potential breach of contract, future business prospects, etc.

Additional information on NEMA and IP Ratings

- The digits or numeral in the NEMA or IP code indicate conformity with the conditions summarized in the Table 1.3 below. The first digit indicates the level of protection that the enclosure provides against the ingress of solid foreign objects. For example, an electrical socket rated IP22 is protected against insertion of fingers and will not be damaged or become unsafe during a specified test in which it is exposed to vertically or nearly vertically dripping water. IP22 or IP2X are common minimum requirements for the design of electrical accessories for indoor use.

NEMA versus IP Enclosure Ratings

NEMA Type	Definition	IEC Equivalent
1	General-purpose. Protects against dust, light, and indirect splashing but is not dust-tight; primarily prevents contact with live parts; used indoors and under normal atmospheric conditions.	IP10
2	Drip-tight. Similar to Type 1 but with addition of drip shields; used where condensation may be severe (as in cooling and laundry rooms).	IP11
3 and 3S	Weather-resistant. Protects against weather hazards such as rain and sleet; used outdoors on ship docks, in construction work, and in tunnels and subways.	IP54
3R	Intended for outdoor use. Provides a degree of protection against falling rain and ice formation. Meets rod entry, rain, external icing, and rust-resistance design tests.	IP14
4 and 4X	Watertight (weatherproof). Must exclude at least 65 GPM of water from 1-in. nozzle delivered from a distance not less than 10 ft for 5 min. Used outdoors on ship docks, in dairies, and in breweries.	IP66
5	Dust-tight. Provided with gaskets or equivalent to exclude dust; used in steel mills and cement plants.	IP52
6 and 6P	Submersible. Design depends on specified conditions of pressure and time; submersible in water; used in quarries, mines, and manholes.	IP67
7	Hazardous. For indoor use in Class I, Groups A, B, C, and D environments as defined in the NEC ®.	N/A

8	Hazardous. For indoor and outdoor use in locations classified as Class I, Groups A, B, C, and D as defined in the NEC ®.	N/A
9	Hazardous. For indoor and outdoor use in locations classified as Class II, Groups E, F, or G as defined in the NEC ®.	N/A
10	MSHA. Meets the requirements of the Mine Safety and Health Administration, 30 CFR Part 18 (1978).	N/A
11	General-purpose. Protects against the corrosive effects of liquids and gases. Meets drip and corrosion-resistance tests.	N/A
12 and 12K	General-purpose. Intended for indoor use, provides some protection against dust, falling dirt, and dripping noncorrosive liquids. Meets drip, dust, and rust resistance tests.	IP52
13	General-purpose. Primarily used to provide protection against dust, spraying of water, oil, and noncorrosive coolants. Meets oil exclusion and rust resistance design tests.	IP54

Table 1.3: NEMA and IP electrical enclosure ratings descriptions, comparison and correspondence.

Example 1.5

Electrical specifications for a factory call for a junction box that must be submersed into a water tank. (a) Determine the NEMA rating of junction box for the US installations. (b) Determine the IP rating of the junction box for the European installations.

Solution:

(a) Examination of the NEMA – IP rating table in this segment shows that NEMA 6 enclosure is rated as:

“Submersible. Design depends on specified conditions of pressure and time; submersible in water; used in quarries, mines, and manholes.”

Therefore, a **NEMA 6 enclosure should be specified** for the US installation.
(b) Since the European installation would be exposed to the same worst case conditions, US NEMA 6's European counterpart, **IP 67 should be specified**.

Common Acronyms Associated with Electrical Standards Organizations

A few organizational acronyms, commonly used in the field of electrical engineering, are listed below with respective background information and website addresses to facilitate further exploration of the roles of these organizations by the reader:

NEMA: National Electrical Manufacturers Association; www.nema.org

NEMA, created in the fall of 1926 by the merger of the Electric Power Club and the Associated Manufacturers of Electrical Supplies, provides a forum for the standardization of electrical equipment, enabling consumers to select from a range of safe, effective, and compatible electrical products.

ANSI: American National Standards Institute; www.ansi.org

The American National Standards Institute (ANSI) is a private, non-profit organization that administers and coordinates the U.S. voluntary standardization and conformity assessment system.

IEC: International Electrotechnical Commission.

IEC is the authoritative worldwide body responsible for developing consensus global standards in the electrotechnical field. IEC is the European counterpart to NEMA and ANSI.

IEEE: Institute of Electrical and Electronic Engineers; www.ieee.org

The IEEE is a non-profit, technical professional association for Electrical and Electronics Engineers. IEEE makes vital contributions in the electrical engineering realm, in many ways. Some of IEEE's more prominent contributions are as follows:

- Publishing of texts and reference material that promote education and training on various electrical and electronic technologies and subjects.
- Development of Arc Flash Hazard Calculation formulas through IEEE 1584 committee.

- Facilitation of the development of protocols that promote communication between various electronic devices.

International Society of Automation (ISA): www.isa.org

Founded in 1945, the International Society of Automation is a leading, global, nonprofit organization that is setting the standard for automation by helping members and other professionals solve difficult technical problems. ISA is based in Research Triangle Park, North Carolina. ISA develops standards, certifies industry professionals, provides education and training, publishes books and technical articles, and hosts conferences and exhibitions for automation professionals.

RIA - Robotics Industries Association: www.robotics.org.

Robotic Industries Association publishes information to help engineers, managers and executives apply and justify robotics and flexible automation. The RIA website includes a proprietary search engine algorithm that makes it easy to find and compare leading companies, products and services. Robotics Online is dedicated to news, articles and information specifically for the robotics industry.

Common Electrical/Electronic Safety Devices

This section introduces the reader to electrical and electronic devices commonly employed in automated control systems and process controls, in general, for safety related actions and events. We will first familiarize the reader to each of the devices, individually. Then, we will discuss integration of the devices in an automated manufacturing system example.

Similar to the pictorial tour approach utilized with the MCC and power distribution system discussion, we will explore Rockwell Automation® safety control devices to gain familiarization with what these devices look like and gain a better understanding about their functions.

Safety E-stop Devices

E-stop switches are, functionally, passive mechanical devices, similar to the light switches in offices and homes. Rockwell/A-B® offer Series 800T/800E Push-Buttons and Self-Monitoring Contact Block based E-stop

switches. The emergency stopping function is implemented through a combination of two components: (1) Push pull operator and (2) Contact block. The description and specification of these two components are as follows:

- **E-Stops Operator**
 - Available in 30mm & 22mm sizes
 - Metal and plastic construction
 - Meet EN418 and IEC 60947-5-5 standards
 - Push-pull, push-pull/twist release, illuminated, or key-operated devices

- **Self-Monitoring Contact Blocks**
 - For use with 800T & 800E E-Stops
 - If contact block becomes separated from E-stop, monitoring circuit automatically opens and shuts down the controlled process. This feature essentially eliminates contact separation concerns from improper installation, damage or high-vibration applications.

Contact Blocks



Operators



Figure 1.8: Rockwell ® Safety E-stop switch operators and contact blocks.

Safety Light Curtain System

Even though safety light curtains often perform emergency stopping function, similar to the emergency stop switches introduced above, they are powered, active, somewhat automated, and substantially more sophisticated than the e-stop switches. See figures 1.9 and 1.10.

● Safety Light Curtain System Consists of:

- Transmitter/Receiver
- Control Reliable Controller
- Interface Cables
- Optional Power Supply
- Optional Muting Blanking control

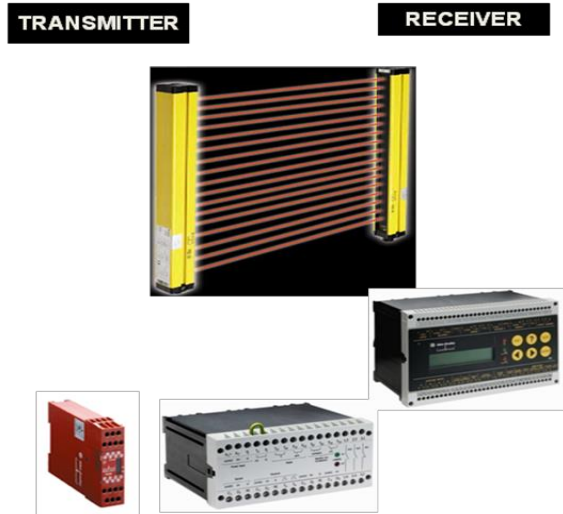

Figure 1.9: Rockwell ® Safety Light Curtain.

Some of the key components of a safety light curtain system are listed in Figure 1.9. As depicted in Figure 1.9, the transmitting “column” transmits an array of invisible (infra-red) light beams. When the path between the transmitter and the receiver is clear and unobstructed, the transmitted beams are received by the receiver. This, in most applications of light curtains, constitutes the norm. If, however, the light beams are interrupted by equipment or personnel, typically, an emergency stop command is generated, thus, shutting down the protected system. The interface cable pictured in Figure 1.9, as simple and unsophisticated as it appears, it constitutes a reliable and robust approach to electrical/control connections. Electrical connections, a decade or so ago, had to be made one wire and one terminal at a time. With hundreds of connections required in mid to large size control systems, the old wire to connector method often resulted in miss-wiring, loose connections, unreliability and delayed system start-ups.

Other important features and components associated with the light curtains are included in Figure 1.10. Rockwell’s ® DNet module (hardware), is an interface module and is pictured in Figure 1.10. The software or protocol

that permits the safety devices, safety PLC's and other Rockwell ® control devices to communicate with each other is referred to as DeviceNet®.

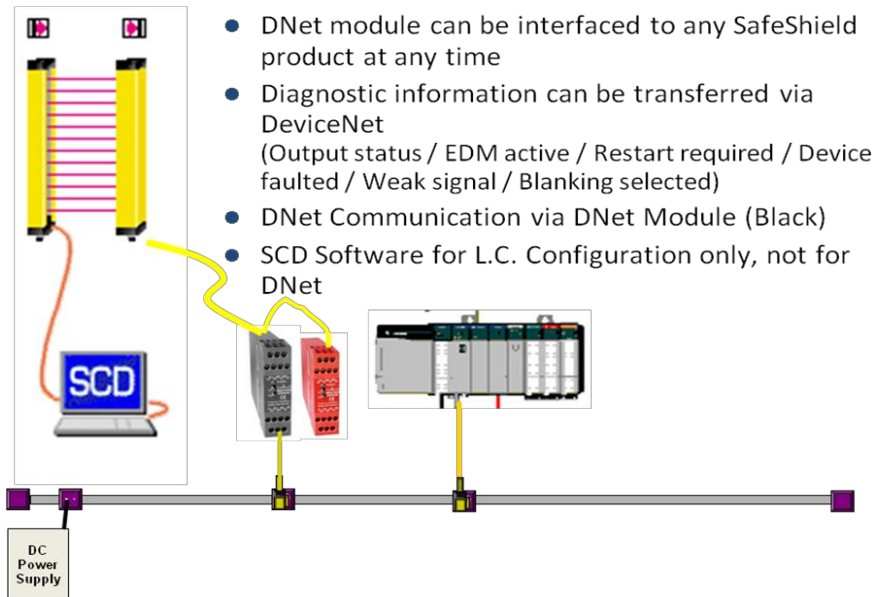

Figure 1.10: SafeShield DeviceNet: Rockwell ® Safety Light Curtain and Device-Net interface.

The laptop PC shown in Figure 1.10 allows control engineers and technicians to configure or “program” the light curtain to respond to safety events in a desired fashion, In addition, the Rockwell ® application software loaded on the laptop allows the controls engineer to *configure “diagnostics”* such that safety incidents and other associated events can be troubleshot promptly.

AAC (Area Access Control)

Area access control system depicted in Figure 1.11 offers a simpler, less costly, less complex alternative to light curtains. Typical area access control system consists of a small single beam transmitter that transmits an infra-red beam across the protected opening, to a pair of prism shaped reflectors. The reflectors return the beam across the opening to a receiver. When the beam is interrupted by personnel or equipment, an emergency stop is triggered by the Area Access Control System. As obvious from a comparison between figures 1.10 and 1.11, the protected opening area of

cross-section covered by a light curtain is greater than the two dimensional area covered by the AAC.

- Long Scan Range up to 70M (230Ft.)
- Die Cast Aluminum Housing
- Two Ranges available
 - - .5M to 18M (19.5" to 59")
 - - 15M to 70M (4' to 230')
- Easy Installation
- Heated Front Screen, I.e. can be used in outdoor applications
- Fast response time 22ms
- 24vd/115vac standard / 230vac (special order)
- Built in monitored safety relays
 - - 2 NO/1NC / 2A Max switching Current
- IP 65 enclosure rating
- Operating temp. -25°C to 50°C
- PG connector IP 67

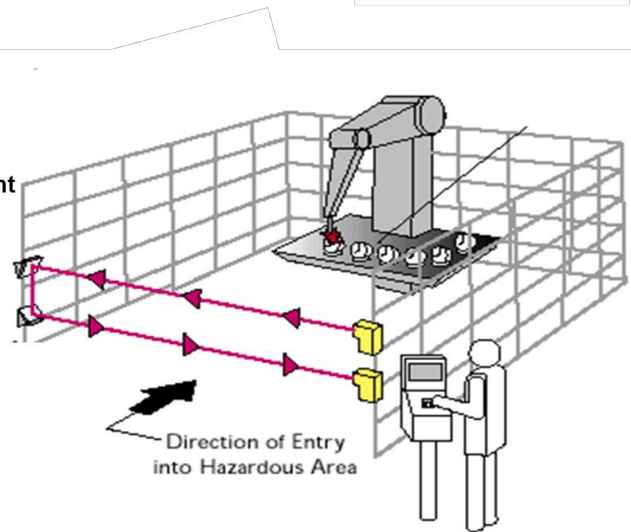

Figure 1.11: Rockwell ® Area Access Control System

Cable Pull Switches

Cable pull safety switches are designed to trip an emergency stop circuit when the cord, cable or chain connected to the pull switch is pulled. Rockwell ® cable pull switches incorporate a reset button on the front of the switch.

Some of the cable pull safety switches are equipped with a tension viewing window to facilitate set-up of the cable tension. Among other important features incorporated in the Rockwell ® cable pull switches is a function that latches out the contacts electrically and mechanically in accordance to EN 418. The reason is that if a person were to pull an ordinary cable pull switch as they were being dragged into a machine, the system would stop, but it would not prevent the system from being restarted at the

other end by an operator, who did not see the switch being pulled. Thus the operator could start the machine again, dragging the other subject back into the machine. In order to reset the lifeline 4 switch, an operator has to physically go up to the switch and reset the device by moving the designated lever into the run position. This allows for inspection of the area, before the machine is restarted. The switch is yellow in accordance to EN 60204-1 which stipulates that all e-stops have a red button and yellow background.

Key Interlock Solenoid Switches

The next family of safety switches offered by Rockwell® are solenoid locking switches. See switches depicted in Figure 1.12. These switches are used to prevent access to a hazardous area until the hazardous motion has been contained. An example would be to have a gate locked until a set of cutting shears have come to rest, after which time a voltage is applied to the coil of the solenoid, releasing the key, allowing access to the area.

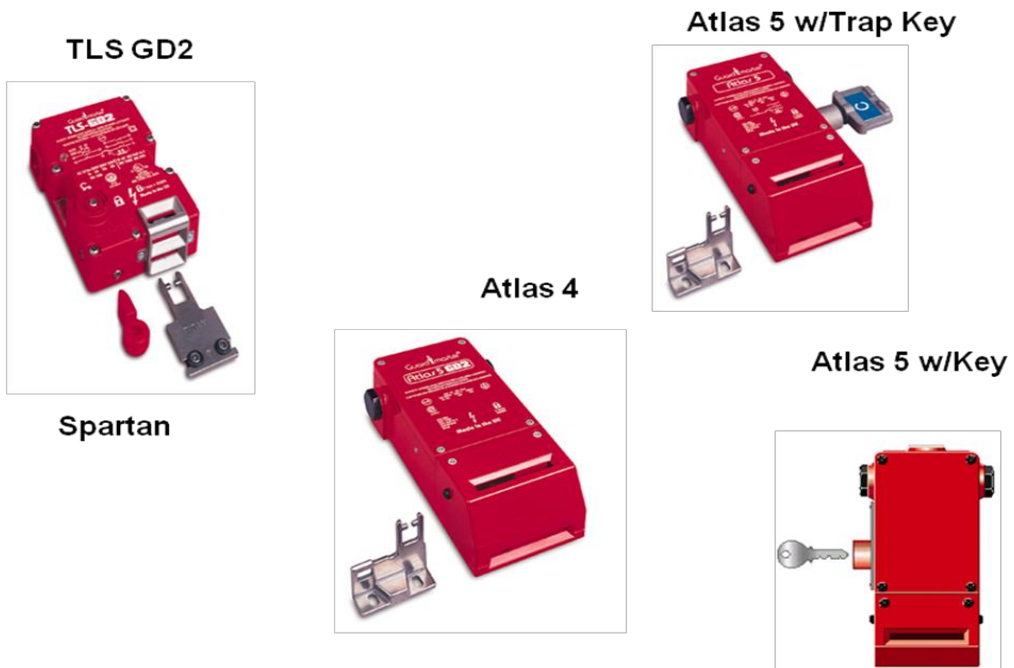

Figure 1.12: Rockwell® Key interlock solenoid safety switch system.

GuardMat™ Safety Mats

Guardmaster offers a full range of standard mats and controllers for all applications. The GuardMat™ system is a tripping device. When a person steps on the mat, or equipment rolls onto it, their presence is detected and the safety output opens, shutting down the machine. See Figure 1.13.

The design of the mat includes two sheets of hardened rolled steel which are separated by small insulators. The separated sheets of metal have an approximate 24 volt potential difference across them. When pressure exceeding 70 psi is applied to the top sheet, the sheets make contact, creating a short circuit condition, changing the resistance, which is detected by the GaurdMat controller. The controller, in turn, executes emergency shut down through system interlocks and safety control circuits.



Controllers



Mats

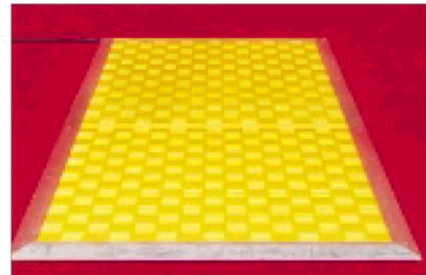

Figure 1.13: Rockwell ® GaurdMat Switch System

GuardEdge™ Safety Edges

The GuardEdge system, is a trip device which lends itself to several applications, as depicted in Figure 1.14. The principle behind this system, is that when the protruding rubber strip – referred to as profile – is depressed, emergency stop signal is issued and the machine shuts down. The rubber profile is impregnated with a conductive carbon powder, which creates a conductive rubber. The system reacts to change in resistance. When the profile is pressed the resistance changes; this change is detected by the

controller. The controller, in turn, executes emergency shut down through safety control circuits.

As apparent in Figure 1.14, a variety of profiles are available to match specific applications. These profiles can be made up to 50 meter in length. The profiles can also be bent to a radius of 200mm to accommodate the most non-linear applications. The safety edges can be wrapped around corners, incorporating active corner connections. The profiles can be wired in series or parallel, depending on system configurations.

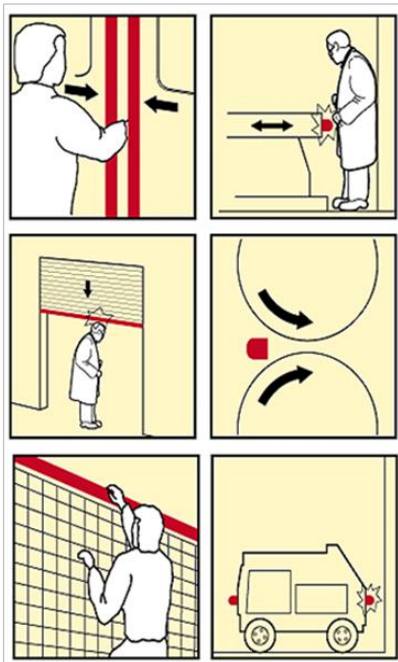

Profiles/Rails and Controllers

Figure 1.14: Rockwell ® GaurdEdge System

Safety PLC's

Traditionally, National Fire Protection Association's "Electrical Standard for Industrial Machinery" (NFPA79) has required hard wiring and the use of electro-mechanical components for safety circuits. With the advent, subsequent development, and enhanced reliability of safety PLC's, electromechanical safety circuits continue to be replaced by safety PLC's. Some of the more significant advantages offered by safety PLC's are as follows:

- Safety PLC based control circuits require fewer wires and terminations as compared to electromechanical relay and contactor based safety control circuits.
- Safety PLC based control circuits require fewer “moving parts,” fewer contactors, timers and relays, if any, as compared to electromechanical relay and contactor based safety control circuits.
- Safety PLC based control circuits are programmable. Therefore, their logic and functionality can be modified through modification of application program or code. While, with electromechanical relay and contactor based safety control circuits, significant hardware and wiring modifications are necessary for accomplishment of functional modification.

Functionally and logically, safety PLC’s are similar to regular PLC’s (Programmable Logic Controllers). Notwithstanding the similarities, there are some notable differences between regular PLC’s and Safety PLC’s. These differences are as follows:

- Safety PLC’s are color-coded **red** to signify the fact that they are “control reliable” and safety rated.
- Safety PLC’s employ **robust diagnostics and operational verification**. Standard PLC inputs provide **no** internal means for testing the functionality of the input circuitry. By contrast, Safety PLCs have an internal ‘output’ circuit associated with each input for the purpose of periodic testing and verification of the input circuitry. Simulated High’s (1’s) and Low’s (0’s) are presented, automatically, to the inputs, to verify their functionality.
- A safety PLC has **redundant microprocessors**, Flash and RAM memory; that are continuously monitored by a “**watchdog**” circuit and a synchronous detection circuit. Regular PLC’s, are typically equipped with **one microprocessor**.
- A regular PLC has one output switching device, whereas a safety PLC’s digital output logic circuit contains a test point after each of

two safety switches located behind the output driver and a third test point downstream of the output driver. Each of the two safety switches is controlled by a unique microprocessor. If a failure is detected at either of the two safety switches, the operating system of a safety PLC will ***automatically acknowledge the anomaly*** and will default to a known state; thus, facilitating an orderly equipment shutdown.

Typical specifications of safety PLC's are listed in Figure 1.15.

- **GuardPLC 2000 and 1200 shipping since August**
 - TÜV Certified (Entire System) - IEC 61508 SIL 3, DIN VDE 19250 AK6, EN 954-1 Category 4,
 - UL Listed
 - Primary Target Market - Machinery Safety
- **GuardPLC 2000 - 6 I/O slot, modular design**
 - 24 Input / 16 Output digital
 - 8 Channel Analog Input & Output (12 bit resolution)
 - 2 Channel HSC (100kHz, 24 bit)
- **Guard 1200 - packaged design**
 - 20 Inputs / 8 Outputs + 2 HSC Inputs (100khz, 24 bit)
- **Communications**
 - Proprietary GuardPLC Ethernet + ASCII
 - Peer to Peer Safety Communications
- **RSLogix Guard Software (2 versions)**
 - Lite and Professional Versions
 - Windows NT/2000
 - RSLogix "Look & Feel"
 - IEC 1131 Function Block Programming
 - User Defined Function Block Capabilities (1755-PCS)



Figure 1.15: Rockwell ® Safety PLC (Programmable Logic Control) System

Safety Relays

A regular relay consists of an electromagnetic coil or solenoid and associated contacts. The solenoid functions in the same manner as described earlier in this text; it operates or controls multiple normally open or normally closed contacts. When a relay is off, its coil is de-energized, its normally open contacts are OPEN, and its normally closed contacts are CLOSED. Conversely, when a relay is turned on, the coil is energized, the normally open contacts are CLOSED and the normally closed contacts are OPEN. A regular relay is shown applied in an alarm circuit in Figure 1.16.

In the schematic diagram of the regular relay shown in Figure 1.16, a relay labeled CR1 (Control Relay 1) is being used to annunciate the status of an **alarm switch**, to the left. The coil of CR1 is connected to neutral “N” on the right side. The other side of CR1 is connected to 110 V only when the alarm switch is operated. As shown in the circuit diagram, the control relay CR1 has two normally open contacts, depicted as two parallel lines and two normally closed contacts shown with a diagonal bar across the parallel lines. When the alarm switch is operated, or closed, the CR1 coil is energized. This closes the normally open CR1 contacts and opens the normally closed contacts. The two normally open contacts are being used to turn on the **alarm horn** and the **red alarm light**. One of the normally closed contacts is being used to maintain the **green light** on, as long as the safety switch is **not** closed. The second normally closed contact is left unconnected, as a spare contact for possible future use.

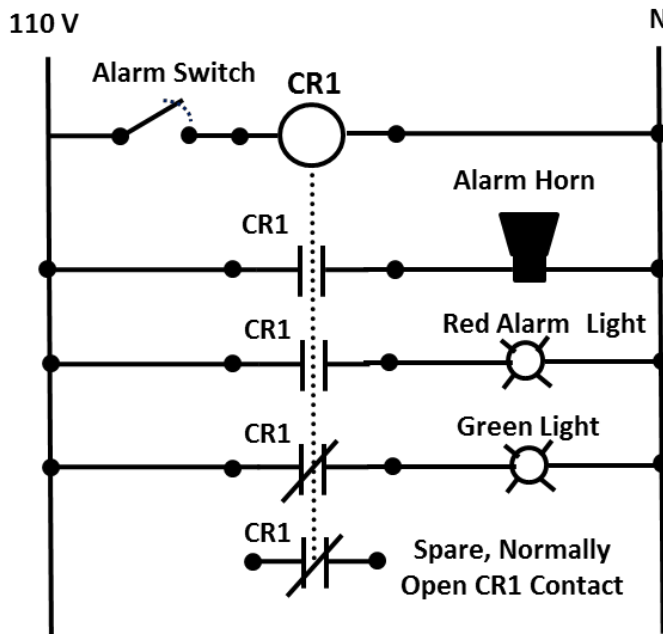

Figure 1.16: Regular relay applied in an alarm circuit.

Safety relays operate somewhat similar to regular relays, with the following exceptions:

- 1) Safety relays are equipped with redundant coils and contacts.

2) Safety relays are equipped with diagnostics features.

Manufacturers, such as Rockwell ®, also offer solid-state relays for applications involving high cycle rates. Safety relays offered by Rockwell ® are shown in Figure 1.17, along with respective features and functions.

- Emergency Stop Relays
 - Monitors the E-stop Circuit
 - Monitors Safety Gate Limit Switches
 - Monitors Light Curtains
 - Monitors Rope Pull Switches

- 2-Hand Control & Safety Gate Monitors
 - 2-Hand Anti-tiedown & Anti-repeat relay
 - Controls machine from safety gate limit switches

- Provides additional safety contacts

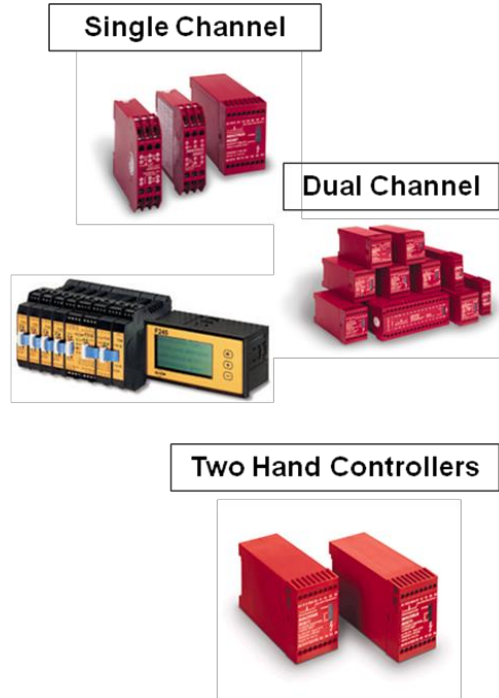

Figure 1.17: Rockwell ® Safety Relays and Contactors

Now that we have gained a measure of familiarity with electrical control and safety devices, let’s explore typical application of some of these devices through a tour of an automated manufacturing cell depicted in Figure 1.18. If we begin at approximately 11:00’o clock and move clock wise, we notice the yellow cabinet housing the *safety PLC* and other safety devices such as safety relays, safety contactors, controllers for various safety devices, i.e. safety mat, safety edge, safety laser scanners, etc. The control cabinet housing the *safety* control devices is painted yellow to distinguish it from typical, gray, control cabinets for regular, *non-safety*, control systems.

At about 1:00’o clock, the common *E-stop switch* is shown mounted on the right side of the processing machine opening. In the diagram, the E-stop switch is labeled as “Safety Button.”

The **safety limit switch** pointed out in the middle of the automated cell diagram limits inadvertent rotation of the robot about its major axis, beyond a safe point. Such application of a safety limit switch, typically, serves as a back-up to a software based rotational limit.

Trapped key safety switch is shown installed on one of the man doors at about 3:00’o clock. A **safety cable pull switch** is shown spanning the length of the conveyor. A **Safety guard** is shown applied just outside a short conveyor section, at about 6:00’o clock, for the purpose of preventing **authorized** personnel in the area from coming too close to moving parts, i.e. the conveyor rollers.

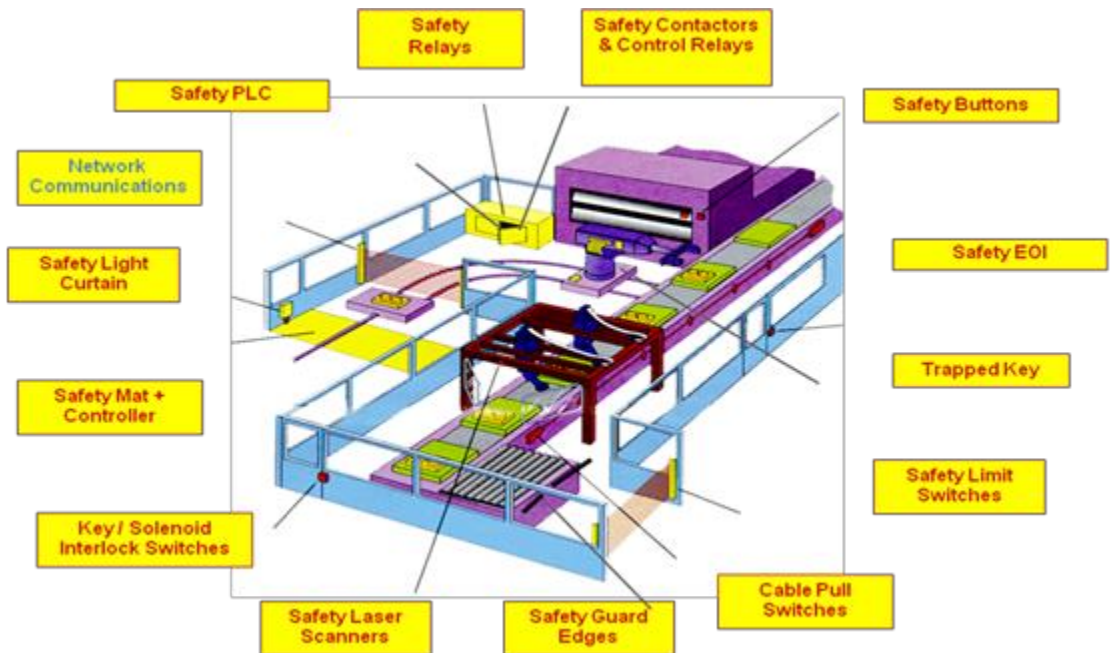

Figure 1.18: Rockwell ® safety equipment applied to an automated manufacturing cell.

A safety laser scanner is shown mounted on the frame that sustains the two gantry robots. This laser scanner is not clearly visible in Figure 1.18. Therefore, a picture of a Rockwell/Allen-Bradley, multi-zone, laser scanner is shown below, in Figure 1.19. Safety laser scanner represents a sophisticated and relatively new approach to three dimensional protection that is not

available through two dimensional safety light curtains, and other less sophisticated safety devices. However, not unlike light curtains, safety laser scanners must be programmed and configured for desired function.

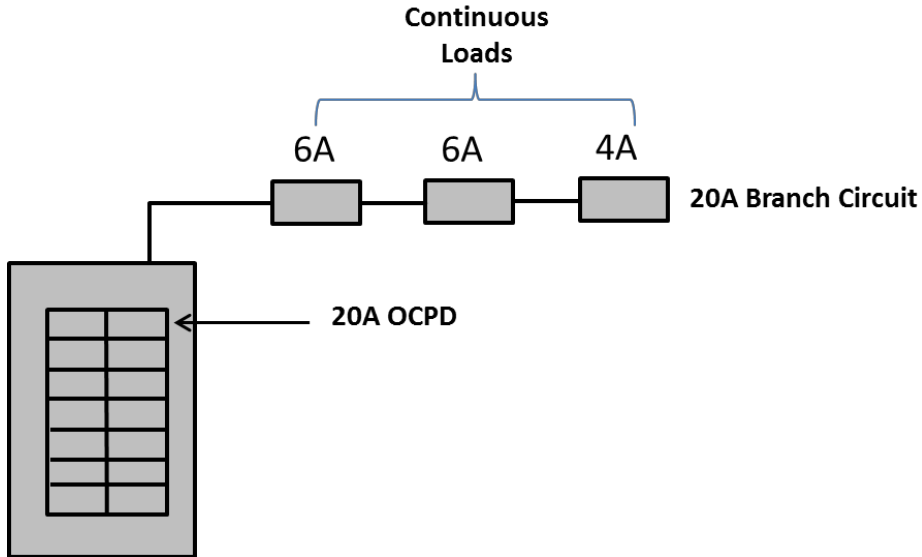

Figure 1.19: Rockwell ® safety laser scanner.

Self-assessment Problems and Questions – Segment 1

1. A given circuit is meant to carry a continuous lighting load of 16 A. In addition, four loads designed for permanent display stands are fastened in place and require 2 A each when operating. What is the rating of the over current protective device (OCPD) on the branch circuit?
2. A three-phase, four-wire feeder with a full-sized neutral carries 14 A continuous and 40 A non-continuous loads. The feeder uses an over current device with a terminal or conductor rating of 60°C. What is the minimum copper conductor size? Assume no derating applies. Use Tables 1.1 and 1.2.
3. Electrical specifications for a brewery company call for a fusible disconnect switch enclosure that must be able withstand occasional splashing of water during periodic wash downs required by the local health codes. This design will be applied in breweries in the US as well as Europe. The water flow from the 1-in wash down nozzles is expected to less than 60 GPM from a distance of 11 ft for less than 4 min. (a) Determine the NEMA rating of enclosure for the US installations. (b) Determine the IP rating of enclosure for the European installations.
4. Over-current Protection & Conductor Ampacity:
Applicable Code/Codes: Articles 210.19 (A) (1), 210.20 (A) and 310.15, and Tables 1.1 and 1.2 of this text (Note: This is not a current table and is only reproduced for exercise and illustration purposes).

The branch circuit in the exhibit below consists of three continuous loads. Over current protection in the branch circuit is provided through a 20 amp circuit breaker. (a) Determine the size of copper conductor based on the ampacities given in Tables 1.1 and 1.2 assuming conductor temperature is at 75°C or less. Assume 75°C operation and selection is allowed. (b) Verify the size/specifications of the circuit breaker. Assume no derating applies. (c) If the ambient temperature were to rise to 50°C, how would the conductor size be impacted?



5. A US appliance manufacturer is planning to market a new appliance in Mexico. The most appropriate safety certification for this appliance would be:

- A. UL
- B. ULC
- C. ETL
- D. NOM

6. Assume that the alarm switch in the control circuit depicted below is opened after being closed for a prolonged period of time. Which of the following conditions would best describe the status of the annunciating lights and the horn when the switch is opened?

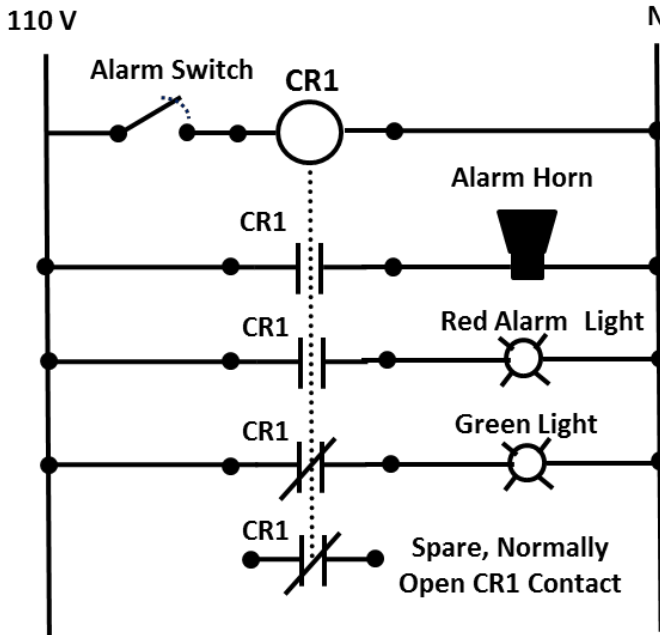

- A. Alarm horn will turn off
- B. Red light will turn off
- C. Green light will turn on
- D. All of the above

Segment 2

Electrical and controls drawings

Introduction

The purpose of this segment is to merely *introduce* the reader to established electrical and controls drawings and drawing best practices. In this segment, the coverage of electrical design drawings, and the application of NEC ® in the associated design work, is *not* intended to provide the reader expert level knowledge that is required and expected of an NEC ® trained and practicing electrical Professional Engineer or electrical power system designer.

However, it is our hope that the nonelectrical engineering professional or non-engineer reader will find this segment helpful in equipping them with enough knowledge to be able to stay abreast of discussion at hand when those electrical and controls drawings are spread across the table in the process of troubleshooting and reinstating an important piece of equipment back into operation. In addition, through a brief introduction to PLC relay ladder logic, we will introduce the reader to the programming technique utilized by most control engineers to control electrical and mechanical systems with PLC based control systems. Of course, as before, we will illustrate the concepts and practices discussed, through examples, end of segment problems, and the solutions at the back of the text.

Electrical Drawings

Three common types of electrical drawings are discussed. These include a one-line power distribution schematic, a wiring diagram and electrical control drawings. The objective of this segment is to inculcate basic understanding of electrical symbols, electrical drawing conventions and electrical design. In addition, the reader will be shown how NEC and other methods for application of the code are employed in the electrical power distribution system design.

One-line Schematic Diagram

The one-line schematic diagram is also, simply, referred to as a “one-line drawing.” This drawing is called a “one-line” drawing because it depicts electrical circuits and design through representation of just one of the three phases. This is predicated on a reasonable assumption that all three phases on the three phase loads and sources are substantially identical in current, voltage, impedance and other important considerations. As obvious, one important benefit derived from one-line representation of electrical circuits is that a greater number of circuits can be captured on one drawing. In other words, one can examine a large portion of the overall electrical system at one glance. This facilitates a quicker and more effective comprehension of a large segment of the electrical system being examined without flipping from one drawing to another. This is of considerable value in a triage situation when trouble shooting a system that is down. A simplified one-line schematic is shown in Figure 2.1. This drawing pertains to an MCC (Motor Control Center) based power distribution system. Due to the extensity of information captured in this diagram, certain segments and annotation are somewhat illegible. Therefore, those segments of the schematic that are examined in greater detail in this segment are excerpted and duplicated in Figure 2.2.

As we examine the one-line schematic, and other drawings, we will note the more conventional symbols and nomenclature, as well as, certain practices adopted by the electrical engineer/designer of these drawings that deviate from the more universally accepted methods. As we examine the top portion of the one-line schematic in Figure 2.1, the first piece of information we notice is the rating of the MCC power distribution system:

480 V Bus, 3 ϕ , 4W, 600A, 60 Hz

This notation represents the rating of the MCC and the specification for the MCC bus bars. This notation encircles one of the three phase bus bars – represented by the long solid line - and it stipulates the following:

- This MCC is rated 480 V
- It is a three phase system
- The MCC is designed to accommodate four wire loads

- It is rated for a maximum of 600A, for 60 Hz application.

The long dashed line represents the outer chassis or MCC cabinet. The solid horizontal line, representing one of the three energized 480 V phases, has multiple vertical lines “hanging” below nodes. These vertical “drops” represent the branch circuits pertaining to specific loads, catered to by this MCC. The dot at the junction of the vertical branch circuit and the horizontal bus represents a “node.” The first branch circuit is identified by a unique identifier “D2,” at the bus bar, on the line side. The other branch circuits are identified as D4, D5, and so on. Note the chevron symbols directly below each branch circuit drop. These symbols represent the MCC cubicle bus stabs, pointed out earlier in the MCC pictures. Focusing on branch circuit D2, and following this circuit down to the load, the next component we notice is the fusible disconnect switch. Refer to Figure 2.2 for a detailed excerpt of branch circuit D2. The three phase, or three pole, “switch” component of the fusible disconnect switch is followed by the associated overcurrent protection fuse. The branch circuit bifurcates after the overcurrent protection fuse into the motor pilot device control circuit and the remaining branch circuit leading to the 3-hp motor in the field. The function and operational logic of the motor pilot device control circuit will be described in the wiring diagram section. As we follow the remaining branch circuit, leading to the motor in the field, the next entity we see is the solid state overload device. The branch circuit exits the MCC chassis on the load side of the overload device, via the terminal strip in the cubicle.

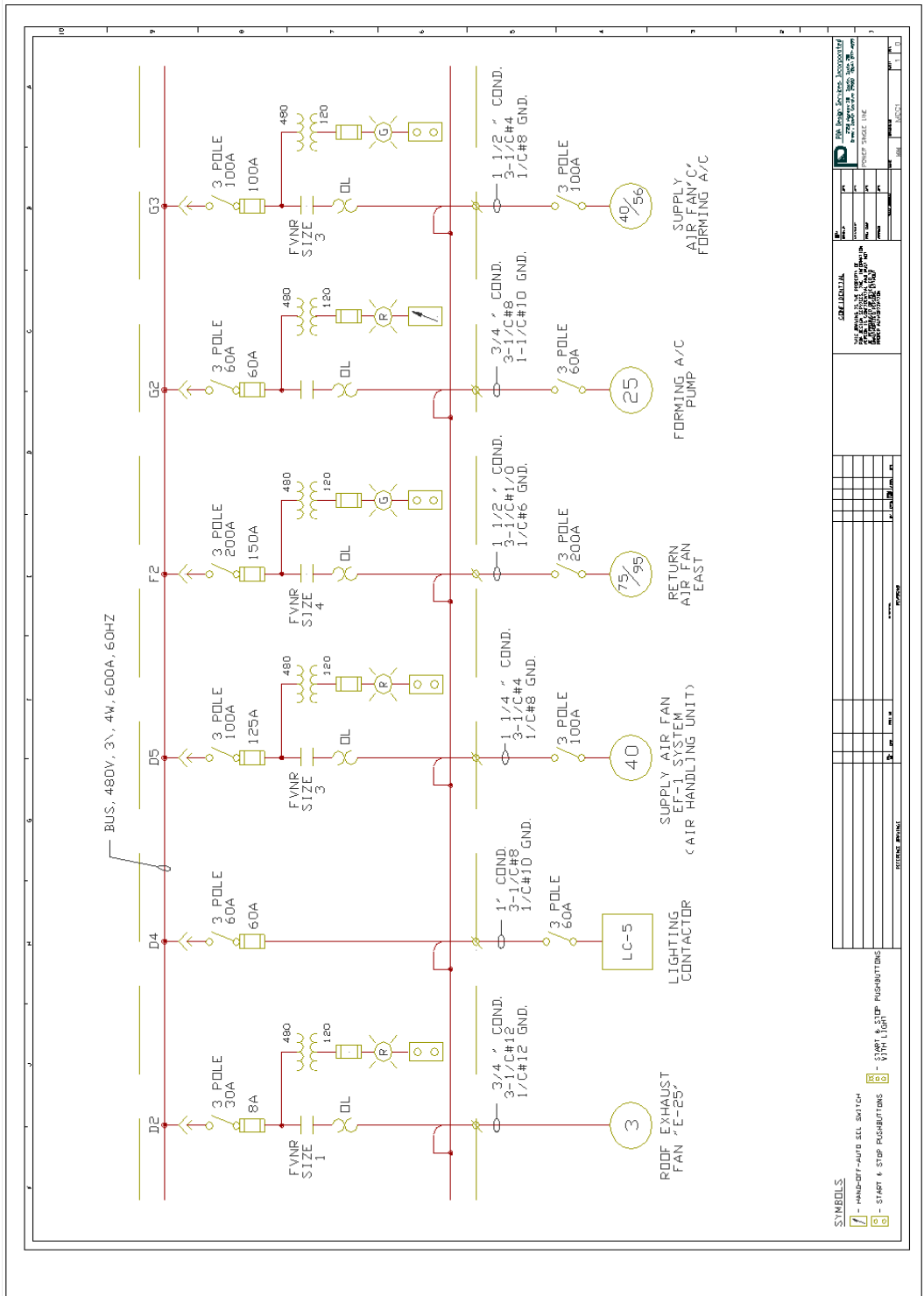

Figure 2.1 – One line schematic for a power distribution system

As labeled in Figure 2.2, the power in branch circuit D2, flows from the MCC to the 3-hp motor, through a bundle of three energized conductors, accompanied by one ground conductor. This bundle of conductors and the conduit are specified on the one-line schematic, and interpreted, as follows:

- **¾” Conduit:** The electrical designer of this power distribution system selected a ¾” (ID) conduit, or pipe, to house the four conductors specified for this branch circuit.
- **3 - 1/C #12:** The electrical designer has selected or specified a three, single (1/C), AWG #12 conductors to supply three phase AC power to the 3-hp motor.
- **1/C #12 Gnd.** The electrical designer has specified one (1/C), AWG #12 conductor to serve as ground for the grounded three phase AC service to the 3-hp motor.

The description of branch circuit symbols and notations provided above should be sufficient for understanding the symbols, nomenclature and notations used for other branch circuits in the one-line schematic depicted in Figure 2.1 with the exception of branch circuit D4. Branch circuit D4 differs from all other branch circuits in that it represents a *lighting load*. Note the square block labeled “LC-5” used to represent the lighting load, instead of the circles used for the motor branch circuits.

Examination of Branch Circuit D2

Having introduced the symbols, nomenclature and labels employed in the representation of power distribution branch circuits, we are better poised to explore and examine the design criteria and specifications incorporated in this one-line schematic. We will verify the following design specifications – pertaining to **branch circuit D2** (Figure 2.1 and 2.2) - in order to give the reader an appreciation of the design process an electrical engineer might go through in designing electrical power distribution systems:

- 1) Current carrying conductor size
- 2) Ground conductor size
- 3) Conduit size
- 4) Overload setting

- 5) Starter size
- 6) Overcurrent protection fuse size
- 7) Fusible disconnect switch size

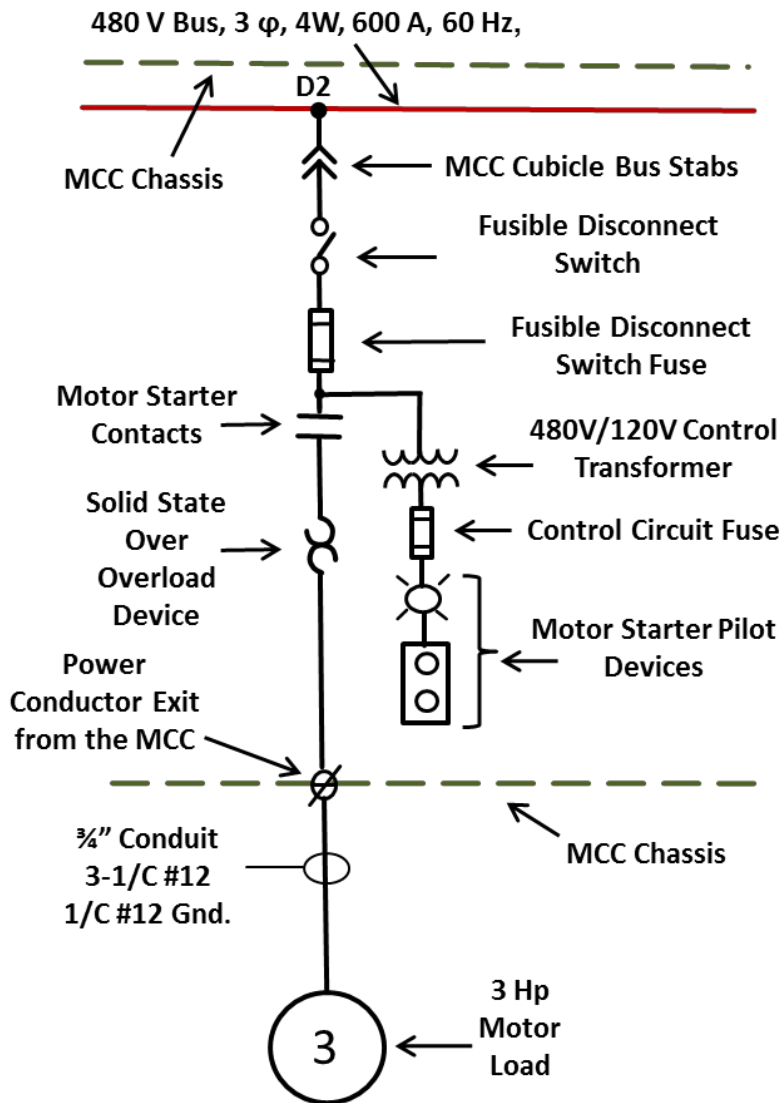

Figure 2.2 – Branch circuit D2 excerpt, from one line schematic for MCC.

Current Carrying Conductor Size

As discussed in the coverage of NEC®, in Segment 1 of this text, a conductor expected to support a certain continuous load must be rated 125% of the full load amps. So, the next step would be to determine the full load amps (FLA) expected to be drawn by the 3-hp motor. As discussed in Segment 1, the code requires that the full load amp information must be based on the “nameplate” of the motor. Since, actual motor data is not available in this text, for illustration purposes we will base our discussion and analysis on the information available in the Buss ® table, shown in Figure 2.3; with some verification through NEC ®.

BUSS® SYSTEM 300 MOTOR PROTECTION GUIDE "NO-DAMAGE" "TYPE 2" SHORT-CIRCUIT PROTECTION OVERLOAD OR BACK-UP OVERLOAD PROTECTION												
Voltage	HP	Fuse Size And Type Protection						Switch Or Feeder Size	Minimum NEMA Starter Size	Minimum Copper Conductor Size†	Minimum Conduit Size‡	
		Over-load		Back-up		Motor Full Load Amps	1.15 S.F. Or Greater Or Rated Not Over 40° C					All Other Motors
		1.15 S.F. Or Greater Or Rated Not Over 40° C	All Other Motors	1.15 S.F. Or Greater Or Rated Not Over 40° C	All Other Motors							
115VAC (120V), 1 ph. (LPN-RK-SP or LPJ-SP)	1/6	4.4	5	5	5.6	5.6	30	00	14	1/2		
	1/4	5.8	7	6.25	7.5	7	30	00	14	1/2		
	1/3	7.2	9	8	9	9	30	0	14	1/2		
	1/2	9.8	12	10	15	12	30	0	14	1/2		
	3/4	13.8	15	15	17.5	17.5	30	0	14	1/2		
	1	16	20	17.5	20	20	30	0	14	1/2		
	1 1/2	20	25	20	25	25	30	1	12	1/2		
	2	24	30	25	30	30	30	1	10	1/2		
	1/2	2.3	2.6	2.5	3	2.8	30	00	14	1/2		
	3/4	3.22	4	3.5	4.5	4	30	00	14	1/2		
	1	4.14	5	4.5	5.6	5	30	00	14	1/2		
	1 1/2	5.98	7	6.25	7.5	7	30	00	14	1/2		
	2	7.82	9	8	10	9	30	0	14	1/2		
	3	11	12	12	15	15	30	0	14	1/2		
	5	17.5	20	20	25	25	30	1	12	1/2		
200V (208V), 3 ph. (LPN-RK-SP or LPJ-SP)	7 1/2	25.3	30	25	35	30	60	1	8	1/2		
	10	32.2	40	35	45	40	60	2	6	3/4		
	15	48.3	60	50	70	60	60	3	4	1		
	20	62.1	75	70	80	75	100	3	3	1		
	25	78.2	90	80	100	90	100	3	1	1 1/4		
	30	92	100	100	125	110	200	4	1/0	1 1/4		
	40	120	150	125	150	150	200	4	1/0	1 1/4		
	50	150	175	150	200	175	200	5	3/0	1 1/2		
	60	177	200	200	225	225	400	5	4/0	2		
	75	221	250	250	300	300	400	5	300	2		
	100	285	350	300	400	350	400	6	500	3		
	125	359	400	400	450	450	600	6	2-4-0	2-2		
	150	414	500	450	600	500	600	6	2-300	2-2		
	230V (240V), 1 ph. (LPS-RK-SP or LPJ-SP)	1/6	2.2	2.5	2.5	2.8	2.8	30	00	14	1/2	
		1/4	2.9	3.5	3.2	4	3.5	30	00	14	1/2	
1/3		3.6	4.5	4	4.5	4.5	30	00	14	1/2		
1/2		4.9	5.6	5.6	6.25	6	30	00	14	1/2		
3/4		6.9	8	7.5	9	8	30	00	14	1/2		
1		8	10	9	10	10	30	00	14	1/2		
1 1/2		10	12	10	15	12	30	0	14	1/2		
2		12	15	12	15	15	30	0	14	1/2		
3		17	20	17.5	25	20	30	1	12	1/2		
5		28	35	30	35	35	60	2	8	1/2		
7 1/2		40	50	45	50	50	60	2	6	3/4		
10		50	60	50	70	60	60	3	4	3/4		
1/2		1	1.25	1 1/4	1.25	1.25	30	00	14	1/2		
3/4		1.4	1.6	1.6	1.8	1.8	30	00	14	1/2		
1		1.8	2.25	2	2.25	2.25	30	00	14	1/2		
1 1/2	2.6	3.2	2.6	3.5	3	30	00	14	1/2			
2	3.4	4	3.5	4.5	4	30	00	14	1/2			
3	4.8	5.6	5	6	5.6	30	0	14	1/2			
5	7.6	9	8	10	9	30	0	14	1/2			
7 1/2	11	12	12	15	15	30	1	14	1/2			
10	14	17.5	15	17.5	17.5	30	1	14	1/2			
15	21	25	20	30	25	30	2	10	1/2			
20	27	30	30	35	35	60	2	8	1/2			
25	34	40	35	45	40	60	2	6	3/4			
30	40	50	45	50	50	60	3	6	3/4			
40	52	60	60	70	60	100	3	4	1			
50	65	80	70	90	75	100	3	3	1			
60	77	90	80	100	90	100	4	1	1 1/4			
75	96	110	110	125	125	200	4	1/0	1 1/4			
100	124	150	125	175	150	200	4	2/0	1 1/2			
125	156	175	175	200	200	200	5	3/0	1 1/2			
150	180	225	200	225	225	400	5	4/0	2			
200	240	300	250	300	300	400	5	350	2 1/2			

* Fuse reducers required. ** 100A switch required.
 † THWN connected to 60°C terminations up to #1. AWG to 75°C terminations for 1/0 and larger. Consult equipment manufacturer for listed termination temperature rating. Higher equipment termination temperature ratings may allow smaller conductor and conduit size.
 ‡ Based on 3 conductors for 3 ph. circuits and 2 conductors for 1 ph. circuits.

MPG

Figure 2.3 – Bus ® Table, used for electrical design verification.

As we focus on the circled/highlighted, section of the Buss ® table in Figure 2.3, we can spot most of the code compliant design parameters associated with the 3-hp load in branch circuit D2. According to this table, a fully loaded 3-phase motor, operating at 480V, will demand 4.8 amps. In addition, according to this table, in order to comply with the code, the three current carrying conductors must be a minimum of AWG #14. If we follow the NEC ® requirement that the conductor ampacity must be a minimum of 125% (1.25) times the motor FLA (Full Load Amps), each of the three current carrying conductors must be capable of carrying a minimum of:

$$(1.25) \times (4.8 \text{ A}) = 6\text{A}$$

Examining Table 2.1 (Superseded by NEC Tables 310.15(B)(2)(a)), we see that an AWG #14 has an ampacity of 20 A, for THHW and THWN insulation (and other types of insulation) at 60°F terminal or conductor temperature. Note, however, that the 20 A ampacity is predicated on other conditions and stipulations, i.e. overcurrent protection restrictions. Further discussion on additional stipulations, exceptions and code implications is outside the scope and context of this text. For simplicity, acknowledging the fact that AWG #14 has the ampacity to carry 20 A (amps), we establish that AWG #14 – as stated in the BUS ® table (Figure 2.4) - is adequate for this motor branch circuit.

Nevertheless, as we refer back to the schematics in figures 2.1 and 2.2, we notice the electrical engineer/designer in this case, selected size AWG #12 copper conductors for this circuit; which is rated 25 A, and it clearly exceeds the minimum requirement. This decision by electrical engineer/designer is an example of how some engineer/designers and engineering firms subscribe to a “**hard deck**” on the low end of conductor sizes. In this case the engineer and the firm appear, as result of “*in-house best practice*,” don’t design power circuits with conductors smaller than AWG #12. The same engineering firm, on the other hand, might design “control” circuits based on AWG #18. Overall, from electrical design safety point of view, selection of AWG #12 for D2 current carrying circuit exceeds the requirements, and is safe.

Ground Conductor Size

Next, let's examine the ground conductor selected for branch circuit D2. As apparent from examination of Bus table in Figure 2.4, this table does not specify the ground conductor size for various branch circuits. One could specify the ***ground conductor*** size to be the same as the ***current carrying conductors***, as done by the designer of branch circuit D2, in schematics on figures 2.1 and 2.2; where the designer specified AWG #12 conductors for the three, 3-hp motor, current carrying conductors, as well as the ground conductor. The purpose of the ground conductor is to carry fault current and to serve as a “mechanism” for safely de-energizing circuits with electrical faults. For example, if the insulation of one of the energized phases in branch circuit D2 were to atrophy, or break down due to other reasons, the 460 V potential could come in contact with the motor chassis and raise its potential to 460 V. With the motor grounded properly, such an electrically unsafe condition would be rectified through a ***phase to ground fault*** clearing the fuse

Table 310.15(B)(2)(a) Adjustment Factors for More Than Three Current-Carrying Conductors in a Raceway or Cable

Size AWG or kcmil	Temperature Rating of Conductor		90°C (194°F)	60°C (140°F)	75°C (167°F)	90°C (194°F)	Size AWG or kcmil
	Types TW, UF	Types RHW, THW, THWN, XHHW, USE, ZW					
18	-	-	14	-	-	-	-
16	-	-	18	-	-	-	-
14*	20	20	25	-	-	-	-
12*	25	25	30	20	20	25	12*
10*	30	35	40	25	30	35	10*
8	40	50	55	30	40	45	8
6	55	65	75	40	50	60	6
4	70	85	95	55	65	75	4
3	5	100	110	65	75	85	3
2	95	115	130	75	90	100	2
1	110	130	150	85	100	115	1
Jan-00	125	150	170	100	120	135	Jan-00
Feb-00	145	175	195	115	135	150	Feb-00
Mar-00	165	200	225	130	155	175	Mar-00
Apr-00	195	230	260	150	180	205	Apr-00
250	215	255	290	170	205	230	250
300	240	285	320	190	230	255	300
350	260	310	350	210	250	280	350
COPPER							
ALUMINUM OR COPPER-CLAD ALUMINUM							

Table 2.1 – NEC ® Ampacity table superseded by current NEC Table 310.15(B)(16). Included for general illustration purposes, only. Courtesy, NEC, NFPA.

protecting that particular “leg” of the branch circuit. The fault events such as the one cited in this example are short lived, and therefore, the ground conductor size and ampacity, do not have to be the same as the size and ampacity of the current carrying conductors. Often, the ground conductor size is less than the current carrying conductors for the same branch circuit.

Ground conductors are sized in accordance with NEC ® Article 250.122 (D) (1) & (2) and Table 250.122. In this case, according to NEC ®, the minimum ground conductor size is AWG #14. So, the AWG #12 ground conductor specified in branch circuit D2 is “oversized,” but safe.

Conduit and Conduit Size

As stated on schematics in figures 2.1 and 2.2, the conduit specified by the engineer is ¾” ID. Before we determine if the ¾” conduit is adequate for this branch circuit, we need to recount the purpose and general characteristics of an electrical conduit. Electrical conduits can be rigid or flexible. Electrical conduits are similar to pipes used to convey fluids. Conduits can be constructed out of metal or PVC (polyvinyl chloride). The key function of an electrical conduit is to protect the electrical conductors against mechanical damage, exposure to adverse environmental ambient factors, i.e. moisture, corrosive liquids, solids or gases. Unlike pipes applied in fluid system, conduits used in electrical systems cannot be filled to completely. As apparent from Segment 1 in this text, and pertinent tables therein, electrical conduits are permitted to be filled only partially. Two ostensible reasons for this constraint are: (1) It is, physically, difficult to pull too many wires through a conduit and associated elbows and fittings (2) a certain minimum, cross-sectional, open space is necessary in an electrical conduit to facilitate ventilation of any heat dissipated in the conductors due to I^2R losses.

The ¾” conduit specified for branch circuit D2, on schematics in figures 2.1 and 2.2, is oversized based on the Bus ® table in Figure 2.4. As noted earlier, the Bus ® table identifies a ½” “conduit for the 3-hp branch circuit D2, in combination with the AWG #14 conductors. The ¾” conduit specified on the drawings is sized based on fact that four AWG #12 conductors were selected by the electrical designer. In order to understand the process of selection of conduits, using the NEC ®, we will compare both alternatives: a ½” conduit and the ¾” conduit.

According to NEC[®], Segment 1, Table 4, a ½” **Rigid Metallic Conduit (RMC)**, with greater than two conductors, can only be filled up to 40% of its internal area of cross-section. The available, internal area of cross-section, according to NEC[®], Segment 1, Table 4 is 81 mm².

According to NEC[®] Chap. 9, Table 5, the total area of cross-section three AWG #14 current carrying conductors would occupy, would be:

$$= 3 \times 8.968 = 26.9 \text{ mm}^2$$

Based on NEC[®], Segment 1, Table 4, 40% fill would require that the minimum internal area of the cross-section of the selected conduit must be:

$$\text{Minimum Area of Cross-section} = \frac{26.9}{0.4} = 67.26 \text{ mm}^2$$

Since this computed minimum area of cross-section of 67.26 mm² is well within the available internal area of cross-section of 81 mm² offered by a ½” RMC, *a ½” conduit for D2 branch circuit would have been adequate, had AWG #14 conductors been used.*

However, since the designer chose AWG #12 for branch circuit D2, according to NEC Chap. 9, Table 5, the total area of cross-section that the three AWG #12 current carrying conductors would occupy, would be:

$$= 3 \times 11.68 = 35 \text{ mm}^2$$

Based on NEC[®], Segment 1, Table 4, 40% fill would require that the minimum internal area of the cross-section of the selected conduit must be:

$$\text{Minimum Area of Cross-section} = \frac{35}{0.4} = 87.6 \text{ mm}^2$$

Since this computed minimum area of cross-section of 87.6 mm² is well within the available internal area of cross-section of 141 mm² offered by a ¾” RMC conduit, a ¾” conduit for D2 branch circuit would be adequate with the AWG #12 conductors specified.

Overload Protection Setting

Overload protection devices are included in motor and branch circuits to protect motors, motor control apparatus, and motor branch circuit conductors against overheating due to overloads. A solid state motor overload device offers flexibility in setting of overload set-points. And motor overload device setting can be determined using the Bus ® Table or NEC ® Article 430.32. In the case of branch circuit D2, according to NEC 430.32 (1) (For separate overload device, for motors other than those with Service Factor of 1.15 and marked operating temperature of 40°C), the overload device should be set at:

$$\begin{aligned} &= 1.15 \times \text{Full Load Amps} \\ &= 1.15 \times 4.8 = 5.52 \text{ A, or simply } 5 \text{ amps.} \end{aligned}$$

According to the Bus ® Table, overload current setting, for this specific case, should be 5 A. So, once again we see the Bus ® Table and the NEC ® yielding, practically, the same results for design specification.

Starter Size

The motor branch circuit starter size is, generally, based on NEMA standards. According to the Bus ® Table, in Figure 2.4, the starter should be “Size 0.” However, once again, we see that the designer of the branch circuit selected a size that is greater than the minimum requirement. The designer of the 3-hp motor branch circuit incorporated a NEMA “Size 1” starter in the schematics shown on figures 2.1 and 2.2.

Overcurrent Protection Fuse Size

As with the motor overload protection device, the selection of motor overcurrent device can be accomplished by using the Bus ® Table or NEC ®. In the case of branch circuit D2, according to NEC 430.52 and Table 430.52 (For a polyphase motor protected by a time-delay fuse) the short circuit fuse must be rated as:

$$\begin{aligned} &= 1.75 \times \text{Full Load Amps} \\ &= 1.75 \times 4.8 = 8.4 \text{ A} \end{aligned}$$

According to NEC ® Article 240.6 (A), when overcurrent calculation yields an ampere specification that is non-standard, the next higher size may

be used. Therefore, a standard 10A fuse could have been selected. Instead, the designer decided to exceed the requirements once again, and chose the standard 8A fuse. As long as the 8 amp fuse does not cause nuisance trips or fuse clearing, it should be acceptable.

Fusible disconnect switch size

The fusible disconnect switch specification can be determined through the Bus ® Table in Figure 2.4. According to the Bus ® Table, at the point of intersection of the row representing 3-hp motor and the column titled: “Switch or Fuse Holder Size,” we see that a 30 A disconnect switch is needed to meet the code. As shown on the one-line diagram in figures 2.1 and 2.2, in compliance with the code, a 30 A disconnect switch is specified by the designer. This is also in compliance with NEC ® Article 430.101 and NEC ®Table 430.251 (B).

So, all in all, it appears that design of branch circuit D2 is in compliance with the code, and in some aspects, it exceeds the code. However, if one compares the design of branch circuit D2 with the rest of the branch circuits, it becomes apparent that, unlike the other branch circuits, D2 lacks a safety disconnect switch at the motor. And, as obvious from the label on the motor load, this motor pertains to a roof exhaust fan and is, possibly, located on the roof; out of line of sight from the MCC disconnect switch. According to NEC ® Article

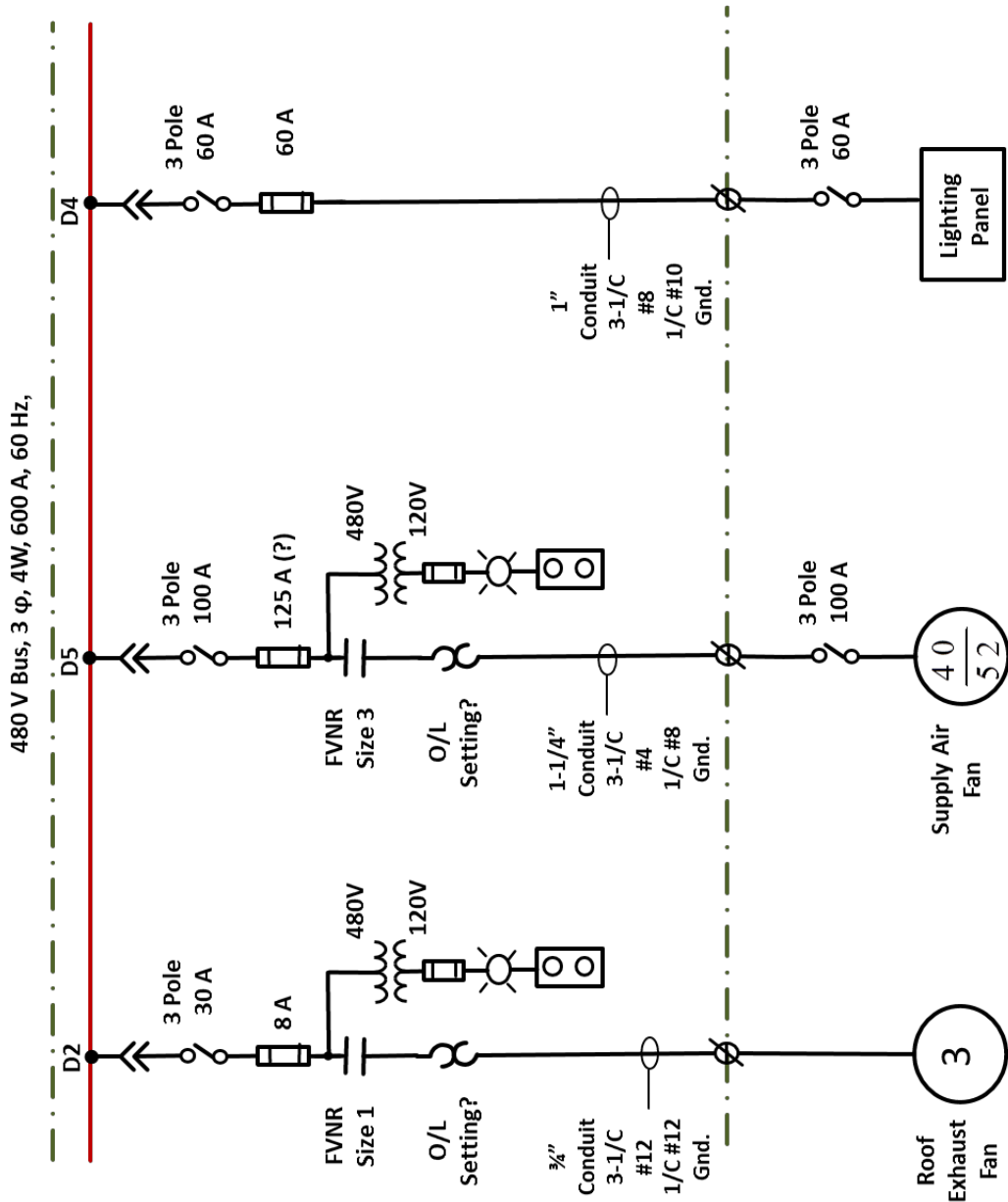

Figure 2.4 – Excerpt, one line schematic for a power distribution system

430.102 (B) (2), the disconnecting means should be located in sight of the motor, barring qualification for exceptions stated under this article. It is unknown if this particular installation qualified for the exceptions. Nevertheless, it is always a desirable, in the interest of safety, to have a lockable disconnect switch at each motor load.

Example 2.1

Answer the following questions pertaining to the branch circuit shown in the schematic diagram below:

- (a) What is the maximum current the power distribution system for this branch circuit rated for?
- (b) What is the turns ratio of the control transformer shown in the motor branch circuit?
- (c) What is the full load current in this circuit?
- (d) What should the solid state overload device be set for at commissioning of this system?

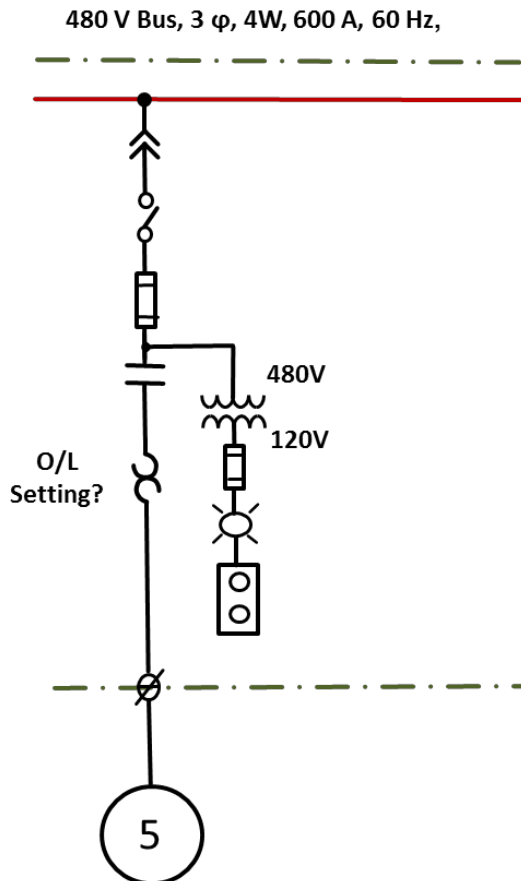

Solution:

(a) The maximum current the power distribution system for this branch circuit rated for is stated in the specification stated at the very top of the schematic diagram, as 600 Amps, within the caption:

“480 V Bus, 3 ϕ , 4W, 600 A, 60 Hz.”

Therefore, the answer is: **600 Amps.**

(b) The turns ratio of the control transformer shown in the motor branch circuit would be based on the voltage transformation stated on the control transformer. As obvious from the schematic diagram, the control transformer has a 480V primary and a 120 V secondary. Apply Eq. 2.1, introduced earlier in this text:

$$\text{Turns Ratio} = \frac{N_P}{N_S} = \frac{V_P}{V_S} \quad \text{Eq. 2.1}$$

$$\text{Turns Ratio} = \frac{N_P}{N_S} = \frac{V_P}{V_S} = \frac{480 \text{ V}}{120 \text{ V}} = \frac{4}{1} = 4:1$$

(c) What is the full load current in this circuit?

This question can be answered through multiple approaches, including the calculation method based on the Equation 2.2, provided the motor efficiency ($\eta_{\text{motor efficiency}}$) and the power factor are known.

$$|S| = \frac{P(\text{watts})}{(\text{pf}) \cdot (\eta_{\text{motor efficiency}})} = |V| \cdot |I|, \text{ or}$$

$$|I| = \frac{P(\text{watts})}{(\text{pf}) \cdot (\eta_{\text{motor efficiency}}) \cdot (|V|)}, \text{ or,} \quad \text{Eq. 2.2}$$

$$|I| = \frac{P(\text{hp}) \cdot (746 \text{ W/hp})}{(\text{pf}) \cdot (\eta_{\text{motor efficiency}}) \cdot (|V|)}$$

Since the efficiency and the power factor are not given, as introduced earlier in this text, we will use the Buss ® table introduced earlier in this segment. As stated in schematic diagram – in the circled motor symbol – the motor’s full load rating is **5 hp**. As specified at the top of schematic diagram, the motor is being powered by a **480 V, 3-phase** source (**480 V Bus, 3 ϕ , 4W, 600 A, 60 Hz**). Therefore, according to the Buss ® table, and as highlighted (circled) below - under the “460 V(480V), 3-ph, section – **the motor full load current would be 7.6 A.**

BUSS® SYSTEM 300 MOTOR PROTECTION GUIDE "NO-DAMAGE" "TYPE 2" SHORT-CIRCUIT PROTECTION OVERLOAD OR BACK-UP OVERLOAD PROTECTION																			
200V (208V), 3 ph. (LPN-RK-SP or LPJ-SP)	HP	Motor Full Load Amps	Fuse Size And Type Protection				Switch Or Feeder Size	Minimum NEMA Starter Size	Minimum Copper Conductor Size†	Minimum Conduit Size	115VAC (120V), 1 ph. (LPN-RK-SP or LPJ-SP)	HP	Motor Full Load Amps	Fuse Size And Type Protection					
			Over-load		Back-up									Over-load		Back-up			
			1.15 S.F. Or Greater Or Rated Not Over 40°C	All Other Motors	1.15 S.F. Or Greater Or Rated Not Over 40°C	All Other Motors								1.15 S.F. Or Greater Or Rated Not Over 40°C	All Other Motors	1.15 S.F. Or Greater Or Rated Not Over 40°C	All Other Motors		
1/6	4.4	5	5	5.6	5.6	30	00	14	1/2	1/6	2.2	2.5	2.5	2.8	2.8	30	00	14	1/2
1/4	5.8	7	6.25	7.5	7	30	00	14	1/2	1/4	2.9	3.5	3.2	4	3.5	30	00	14	1/2
1/3	7.2	9	8	9	9	30	0	14	1/2	1/3	3.6	4.5	4	4.5	4.5	30	00	14	1/2
1/2	9.8	12	10	15	12	30	0	14	1/2	1/2	4.9	5.6	5.6	6.25	6	30	00	14	1/2
3/4	13.8	15	15	17.5	17.5	30	0	14	1/2	3/4	6.9	8	7.5	9	8	30	00	14	1/2
1	16	20	17.5	20	20	30	0	14	1/2	1	8	10	9	10	10	30	00	14	1/2
1 1/2	20	25	20	25	25	30	1	12	1/2	1 1/2	10	12	10	15	12	30	0	14	1/2
2	24	30	25	30	30	30	1	10	1/2	2	12	15	12	15	15	30	0	14	1/2
1/2	2.3	2.6	2.5	3	2.8	30	00	14	1/2	3	17	20	17.5	25	20	30	1	12	1/2
3/4	3.22	4	3.5	4.5	4	30	00	14	1/2	5	28	35	30	35	35	60	2	8	1/2
1	4.14	5	4.5	5.6	5	30	00	14	1/2	7 1/2	40	50	45	50	50	60	2	6	3/4
1 1/2	5.98	7	6.25	7.5	7	30	00	14	1/2	10	50	60	50	70	60	60	3	4	3/4
2	7.82	9	8	10	9	30	0	14	1/2	1/2	1	1.25	1 1/4	1.25	1.25	30	00	14	1/2
3	11	12	12	15	15	30	0	14	1/2	3/4	1.4	1.6	1.6	1.8	1.8	30	00	14	1/2
5	17.5	20	20	25	25	30	1	12	1/2	1	1.8	2.25	2	2.25	2.25	30	00	14	1/2
7 1/2	25.3	30	25	35	30	60	1	8	1/2	1 1/2	2.6	3.2	2.6	3.5	3	30	00	14	1/2
10	32.2	40	35	45	40	60	2	6	3/4	2	3.4	4	3.5	4.5	4	30	00	14	1/2
15	48.3	60	50	70	60	60	3	4	1	3	4.8	5.6	5	6	6	30	0	14	1/2
20	62.1	75	70	80	75	100	3	3	1	5	7.6	9	8	10	9	30	0	14	1/2
25	78.2	90	80	100	90	100	3	1	1 1/4	7 1/2	11	13	12	15	15	30	1	14	1/2
30	92	100	100	125	110	200	4	1/0	1 1/4	10	14	17.5	15	17.5	17.5	30	1	14	1/2
40	120	150	125	150	150	200	4	1/0	1 1/4	15	21	25	20	30	25	30	2	10	1/2
50	150	175	150	200	175	200	5	3/0	1 1/2	20	27	30	30	35	35	60	2	8	1/2
60	177	200	200	225	225	400	5	4/0	2	25	34	40	35	45	40	60	2	6	3/4
75	221	250	250	300	300	400	5	300	2	30	40	50	45	50	50	60	3	6	3/4
100	285	350	300	400	350	400	6	500	3	40	52	60	60	70	60	100	3	4	1
125	359	400	400	450	450	600	6	2-4/0	2-2	50	65	80	70	90	75	100	3	3	1
150	414	500	450	600	500	600	6	2-300	2-2	60	77	90	80	100	90	100	4	1	1 1/4
										75	96	110	110	125	125	200	4	1/0	1 1/4
										100	124	150	125	175	150	200	4	2/0	1 1/2
										125	156	175	175	200	200	5	3/0	1 1/2	
										150	180	225	200	225	225	400	5	4/0	2
										200	240	300	250	300	300	400	5	350	2 1/2

* Fuse reducers required. ** 100A switch required.
 † THWN connected to 60°C terminations up to #1. AWG to 75°C terminations for 1/0 and larger. Consult equipment manufacturer for listed termination temperature rating. Higher equipment termination temperature ratings may allow smaller conductor and conduit size.
 ‡ Based on 3 conductors for 3 ph. circuits and 2 conductors for 1 ph. circuits.

MPG

(d) Using the Buss ® table above, for 3 – phase, 5 hp motor, operating at a 480 V, the overload device should be set at 8.0 A.

Note: If NEC tables were used here, the 115% multiplier by NEC ® would result in an overload setting of 8.7 A.

Examination of Branch Circuit D5

While we will not examine branch circuit D5 to the degree we examined D2, it is important to point out one apparent oversight on the part of the designer. This oversight pertains to the overcurrent protection fuse specification of 125 A, as it appears on the one-line drawing in figures 2.1 and 2.2.

BUSS® SYSTEM 300 MOTOR PROTECTION GUIDE "NO-DAMAGE" "TYPE 2" SHORT-CIRCUIT PROTECTION OVERLOAD OR BACK-UP OVERLOAD PROTECTION															
200V (208V), 3 ph. (LPS-RK-SP or LPJ-SP)	HP	Fuse Size And Type Protection										Switch Or Fuseholder Size	Minimum NEMA Starter Size	Minimum Copper Conductor Size†	Minimum Conduit Size‡
		Motor Full Load Amps		1.15 S.F. Or Greater Or Rated Not Over 40°C		All Other Motors		1.15 S.F. Or Greater Or Rated Not Over 40°C		All Other Motors					
		Over-load	Back-up	Over-load	Back-up	Over-load	Back-up	Over-load	Back-up						
1/6	4.4	5	5	5.6	5.6	30	00	14	1/2						
1/4	5.8	7	6.25	7.5	7	30	00	14	1/2						
1/3	7.2	9	8	9	9	30	0	14	1/2						
1/2	9.8	12	10	15	12	30	0	14	1/2						
3/4	13.8	15	15	17.5	17.5	30	0	14	1/2						
1	16	20	17.5	20	20	30	0	14	1/2						
1 1/2	20	25	20	25	25	30	1	12	1/2						
2	24	30	25	30	30	30	1	10	1/2						
1/2	2.3	2.6	2.5	3	2.8	30	00	14	1/2						
3/4	3.22	4	3.5	4.5	4	30	00	14	1/2						
1	4.14	5	4.5	5.6	5	30	00	14	1/2						
1 1/2	5.98	7	6.25	7.5	7	30	00	14	1/2						
2	7.82	9	8	10	9	30	0	14	1/2						
3	11	12	12	15	15	30	0	14	1/2						
5	17.5	20	20	25	25	30	1	12	1/2						
7 1/2	25.3	30	25	35	30	60	1	8	1/2						
10	32	40	35	45	40	60	2	6	3/4						
15	48.3	60	50	70	60	60	3	4	1						
20	62.1	75	70	80	75	100	3	3	1						
25	78.2	90	80	100	90	100	3	1	1 1/4						
30	92	100	100	125	110	200	4	1/0	1 1/4						
40	120	150	125	150	150	200	4	1/0	1 1/4						
50	150	175	150	200	175	200	5	3/0	1 1/2						
60	177	200	200	225	225	400	5	4/0	2						
75	221	250	250	300	300	400	5	3/0	2						
100	285	350	300	400	350	400	6	5/0	3						
125	359	400	400	450	450	600	6	2-4/0	2-2						
150	414	500	450	600	500	600	6	2-3/0	2-2						

BUSS® SYSTEM 300 MOTOR PROTECTION GUIDE "NO-DAMAGE" "TYPE 2" SHORT-CIRCUIT PROTECTION OVERLOAD OR BACK-UP OVERLOAD PROTECTION															
230V (240V), 1 ph. (LPS-RK-SP or LPJ-SP)	HP	Fuse Size And Type Protection										Switch Or Fuseholder Size	Minimum NEMA Starter Size	Minimum Copper Conductor Size†	Minimum Conduit Size‡
		Motor Full Load Amps		1.15 S.F. Or Greater Or Rated Not Over 40°C		All Other Motors		1.15 S.F. Or Greater Or Rated Not Over 40°C		All Other Motors					
		Over-load	Back-up	Over-load	Back-up	Over-load	Back-up	Over-load	Back-up						
1/6	2.2	2.5	2.5	2.8	2.8	30	00	14	1/2						
1/4	2.9	3.5	3.2	4	3.5	30	00	14	1/2						
1/3	3.6	4.5	4	4.5	4.5	30	00	14	1/2						
1/2	4.9	5.6	5.6	6.25	6	30	00	14	1/2						
3/4	6.9	8	7.5	9	8	30	00	14	1/2						
1	8	10	9	10	10	30	00	14	1/2						
1 1/2	10	12	10	15	12	30	0	14	1/2						
2	12	15	12	15	15	30	0	14	1/2						
3	17	20	17.5	25	20	30	1	12	1/2						
5	28	35	30	35	35	60	2	8	1/2						
7 1/2	40	50	45	50	50	60	2	6	3/4						
10	50	60	50	70	60	60	3	4	3/4						
1/2	1	1.25	1 1/4	1.25	1.25	30	00	14	1/2						
3/4	1.4	1.6	1.6	1.8	1.8	30	00	14	1/2						
1	1.8	2.25	2	2.25	2.25	30	00	14	1/2						
1 1/2	2.6	3.2	2.6	3.5	3	30	00	14	1/2						
2	3.4	4	3.5	4.5	4	30	00	14	1/2						
3	4.8	5.6	5	6	5.6	30	0	14	1/2						
5	7.6	9	8	10	9	30	0	14	1/2						
7 1/2	11	12	12	15	15	30	1	14	1/2						
10	14	17.5	15	17.5	17.5	30	1	14	1/2						
15	21	25	20	30	25	30	2	10	1/2						
20	27	30	30	35	35	60	2	8	1/2						
25	34	40	35	45	40	60	2	6	3/4						
30	40	50	45	50	50	60	3	6	3/4						
40	52	60	60	70	60	100	3	4	1						
50	65	80	70	90	75	100	3	3	1						
60	77	90	80	100	90	100	4	1	1 1/4						
75	96	110	110	125	125	200	4	1/0	1 1/4						
100	124	150	125	175	150	200	4	2/0	1 1/2						
125	156	175	175	200	200	200	5	3/0	1 1/2						
150	180	225	200	225	225	400	5	4/0	2						
200	240	300	250	300	300	400	5	350	2 1/2						

* Fuse reducers required. ** 100A switch required.
 † THWN connected to 60°C terminations up to #1. AWG to 75°C terminations for 1/0 and larger. Consult equipment manufacturer for listed termination temperature rating. Higher equipment termination temperature ratings may allow smaller conductor and conduit size.
 ‡ Based on 3 conductors for 3 ph. circuits and 2 conductors for 1 ph. circuits.

Figure 2.5 – Excerpt, one line schematic for a power distribution system

See the circled data, in Figure 2.5 Bus ® table, for full load amps associated with a 40-hp motor. In the case of branch circuit D5, which supports a 40-hp (52 FLA, Full Load Amps, as stated under the column adjacent to the HP column) motor, according to NEC 430.52 and Table 430.52 (For a polyphase motor protected by a time-delay fuse) the short circuit fuse must be rated as:

$$= 1.75 \times \text{Full Load Amps}$$

$$= 1.75 \times 52 = 91 \text{ A}$$

According to NEC ® Article 240.6 (A), when overcurrent calculation yields an ampere specification that is non-standard, the next higher size may be used. Therefore, standard 100 A fuses should have been selected. Instead, the designer chose a 125 A overcurrent protection fuse. In the absence of possible qualifying exceptions, this branch circuit should be equipped with a combination of a 100 A fusible disconnect switch (see 4th column from the right) and 100 A short circuit protection fuses.

Examination of Branch Circuit D4

As apparent from the load identifying symbol, LC-5, this branch circuit supplies power to lighting load of 5-hp. The 60 A disconnect switches and the 60 A fuses are based on NEC ® Article 430. Note that the Bus ® chart cannot be used in the case of lighting loads.

Wiring Diagram

Unlike a one-line schematic, a wiring diagram displays comprehensive information on all three phases of a three phase AC system, along with the associated grounds. See Figure 2.6. The wiring diagram in Figure 2.6 pertains to three motor loads: 40-hp supply air fan motor, 75-hp return air fan motor, and a 15-hp pump motor. We will limit our focus the 75-hp return air motor circuit, on the left. Notice the vertical lines, spanning from top to bottom, on the left side of the wiring diagram. These lines, as annotated on the drawing, represent the voltage bearing phase busses A, B and C; as well as the ground bus (G).

As we work our way from the left side of this 75-hp motor circuit to the right, we notice the three energized phase busses are “tapped” by the 75-hp branch circuit via the bus stabs, represented by the “chevron” symbols. The MCC ground is shown routed from the MCC to the three phase AC 75-hp return air motor. All three phases are shown bridged from the MCC bus stabs to the 200 A disconnect switch, labeled as “3 Pole, 200A.” Each of the three phases is then routed to respective motor starter contactor contacts via the short circuit protection fuses. Note the strict adherence of unique labeling assigned to each continuous conductor, between consecutive current interrupting points. For instance, the wire label “1L1” is reserved for the conductor between the load side of phase A 150 A fuse and the motor starter contact, labeled “Size 4 M;” where “M” represents the motor contactor for

this circuit. Unique numbering of conductors is crucial for the following few reasons:

- a) Troubleshooting and tracing of circuits, using a drawing.
- b) Ensuring that wires are not “cross-wired.” Crossed wires can result in phase to phase and phase to ground faults, and control circuit malfunctions.
- c) Unique wiring facilitate accurate wiring or assembly of power distribution and control circuits.

Application of wiring numbers is not feasible when wire type conductor are not used to connect one current interrupting point to another, such as the connection between a motor starter contact and an overload contact, as evident on Figure 2.6 wiring diagram.

Wires T1, T2 and T3 connect phases A, B and C to respective line side terminals of the safety disconnect switch poles at the motor, in the field. Note that the identification of wires, completing the final connection of phases A, B and C to the motor terminals, changes to 1T1, 1T2 and 1T3, respectively.

The pilot device and control power for this 75-hp motor is shown “tapped” or branched off phases A and B. This phase to phase power, as expected, would be 480 V. However, the control circuit must be 120 V or less. Therefore, the tapped 480 V power, as shown on the wiring diagram, is “stepped down” to 120V through the 480/120 V control transformer. Note that the secondary of this control transformer is grounded on one leg. This leg, serves as a neutral, ground or low potential point. The other terminal, then, serves as the higher potential, 120 V, point, labeled as X1. This 120 V and neutral pair sustains and operates all of the pilot devices, switches, interlock contacts and motor contactor coil.

The 120 V control power is protected through a fuse and arrives at the “STOP” switch’s normally open contacts via conductor numbered as “1.” The spring loaded, momentary, STOP push button contact is normally closed, as shown in the wiring diagram. So, the 120 V potential crosses over to point 1A and three safety interlock contacts. These contacts are normally open. Such interlock contacts are often associated with system components such as doors – which must be closed before the motor is allowed to be energized. Let’s

assume that all safety conditions are met in this case. This would allow us to assume that all three of these interlock contacts are closed. Then 120 control voltage would bridge over to point 26 on wiring diagram. Point 26 and the terminal labeled “2” are at the same potential; there is an electrical short between these two points. Therefore, terminal 2 retains 120 V potential as long as the STOP button is *not* depressed. Then, if the START switch is

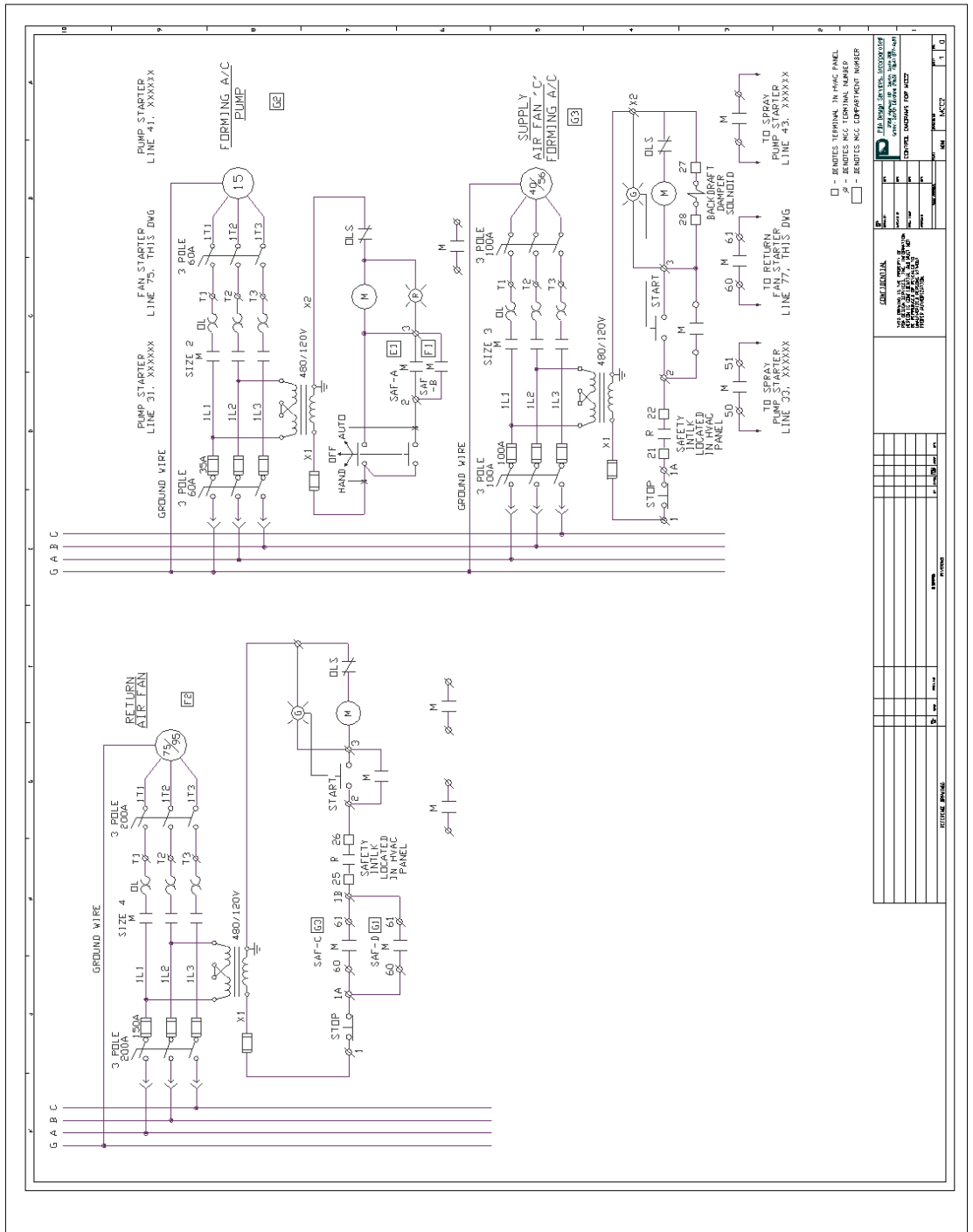

Figure 2.6 – Wiring diagram for power distribution system

depressed, its normally open contacts close allowing the 120 control voltage to be applied to the coil of the motor starter contactor “M.” Since neutral or ground side of the coil is always grounded through the normally closed solid state overload contacts (unless the overload protection device has tripped under an overload condition), the motor starter coil energizes when the START switch is depressed. The three motor starter contacts, shown in the motor branch circuit, close; thus, releasing three phase voltage and power to the 75-hp motor. Since the *pilot light* for the motor is connected in parallel with the motor starter coil, the motor “ON” light turns on, as well. One of the motor starter contacts, referred to as the “latching contact “M” is connected in parallel with the START switch contacts. This contact seals the coil in energized mode, such that when the START button is released, the motor starter coil stays latched and the motor continues to operate. The motor continues to operate as long as all of the safety interlocks stay closed, the overload protection device does not sense an overload, and the STOP switch is not depressed.

When the motor STOP switch is depressed, its normally closed contacts open and the continuity of the 120 V circuit is broken. This results in de-energization of the motor starter coil, thus *unlatching* the sealing contacts of the motor starter coil. The motor ceases to operate.

The control sequence and logic described above represents the essence of approaches applied in most motor starter circuits, with some application specific variations.

Control Diagram/Drawing

Our discussion in this section will be based on the control diagrams depicted in figures 2.7 and 10.8. Both of these drawings are based on a control system premised on a PLC, Programmable Logic Controller. In other words, the control algorithm is being implemented through a control architecture where the PLC CPU, Central Processing Unit, makes all control decisions in accordance with the PLC control program. Of course, the CPU makes the control decisions in *response* to the current state or change of state of all pertinent inputs.

The control drawing, or control schematic, in Figure 2.7 shows some of the inputs interfaced to, or monitored by, the PLC. The inputs are, essentially, signals coming from sensors and switches in the field. These

signals can be “discrete” or “digital;” meaning, they are in form of “ON’s,” “OFF’s,” “1’s,” “0’s,” switch *closed* or *open*, etc. The column to the right of the drawing, labeled with input numbers, i.e. Input 1, Input 2, and so on, represents a PLC input module. Note that this module is labeled as 115VAC Input, Modicon, Cat. No: B805-016. The role of this input module is to receive 115V AC signals from various sensors and switches in the field and convert them into low voltage DC signals. A 115 or 120 VAC signal is transduced by the input module circuitry into a $5V_{DC}$ or $10V_{DC}$ signal. An absence of AC voltage at a given input is converted into $0V_{DC}$ and interpreted as a “0.” When a 115 V signal is received at an input point, it is interpreted by the PLC as a “1.” In other words, the PLC expects discrete **1’s** and **0’s** from its input modules.

The output module shown in Figure 2.8 serves as an interface between the PLC and the control devices/equipment in the field in a manner similar to the input module. However, there are a few distinct differences. A discrete 115 VAC output module, *receives* discrete signals, 1’s and 0’s, *from* the PLC CPU and *converts them* into 115 VAC or 0 VAC outputs or commands - that are conveyed to the control devices in the field, such as, motor starter coils, solenoids, lamps, horns, etc. - as shown on the right side of the control drawing in Figure 2.8. Notice that contiguous electrical connections or wires are identified by unique numbers or alphanumeric identifications on the input and the output control drawings.

Input Control Diagram

In order to get a better understanding of how the inputs from various field sensors and switches interface with the PLC, let’s focus on the input control drawing in Figure 2.7 and follow a hypothetical, yet plausible, scenario. We will then extend the possible outcome of this hypothetical scenario to the output control diagram on Figure 2.8.

Let’s assume that pressure switch, PSxxx56, shown in Figure 2.7, is monitoring the pressure in a vessel that must be maintained above a certain critical, level. This pressure switch is *normally open*, but *closed* when the vessel is pressurized, as shown in the control drawing. In this safe state, with the pressure switch closed, 120 V control voltage is passed on to Input #1 on the PLC input module. As described earlier, the 120 V potential at Input #1 gets transduced into a logic level “1” for interpretation by the CPU

(microprocessor). As long as the pressure switch remains closed, Input #1 maintains a logic value of “1.” If the pressure switch opens, 120 V at Input #1 would disappear and logic level “1” would be replaced by a logic level “0.” Often switches – such as the pressure switch in this circuit - are applied such that they *open* under “*unsafe*” conditions. When electrical control devices are applied in this manner, they are said to be in “*fail safe*” mode. If the vessel in this scenario were to lose pressure to a level below a preset critical level, the pressure switch will open. The set point, in such a case could be set at the pressure switch. The temperature of a downstream process in this scenario, is being monitored by a temperature switch TSxxx60. See Figure 2.7. The process, downstream, relies on pressure in the vessel being maintained at an adequate level. This temperature switch is open under normal circumstances and would close only if safe operating temperature is exceeded. Note that this temperature switch is *not* applied in *fail safe* mode. Under normal operation, the temperature switch is open, and the 120 V control voltage stops at the left side of the temperature switch. This results in 0 V at Input #3. No voltage at terminal #3 of the PLC input module translates into logic level “0” at Input #3. The PLC CPU, or microprocessor, completes execution of one cycle of the control program, on average, in approximately, 30 milliseconds. So, as the CPU examines Input #3, every 30 milliseconds, it sees a “0” and interprets that as a normal situation, requiring no specific action by the PLC system.

Now, let’s assume that pressurized vessel develops a leak and loses pressure, to the extent that the pressure switch opens. As the pressure switch opens, the 120 V control voltage at Input #1 disappears, resulting in the change of input #1 logic state from a “1” to a “0.” At the same time, as the pressure in the vessel drops below critical level, the temperature of the process rises to critical level, and the temperature switch closes. The 120 V control voltage is bridged across to PLC input module input #3, changing its logic state from a “0” to a “1.” At the very next scan, the PLC senses the change of state at inputs #1 and #3. The PLC logic and algorithm recognizes these two changes of state as an anomaly and develops a logical solution that it must execute through its outputs. This juncture serves as an appropriate segue into the output section of the control system.

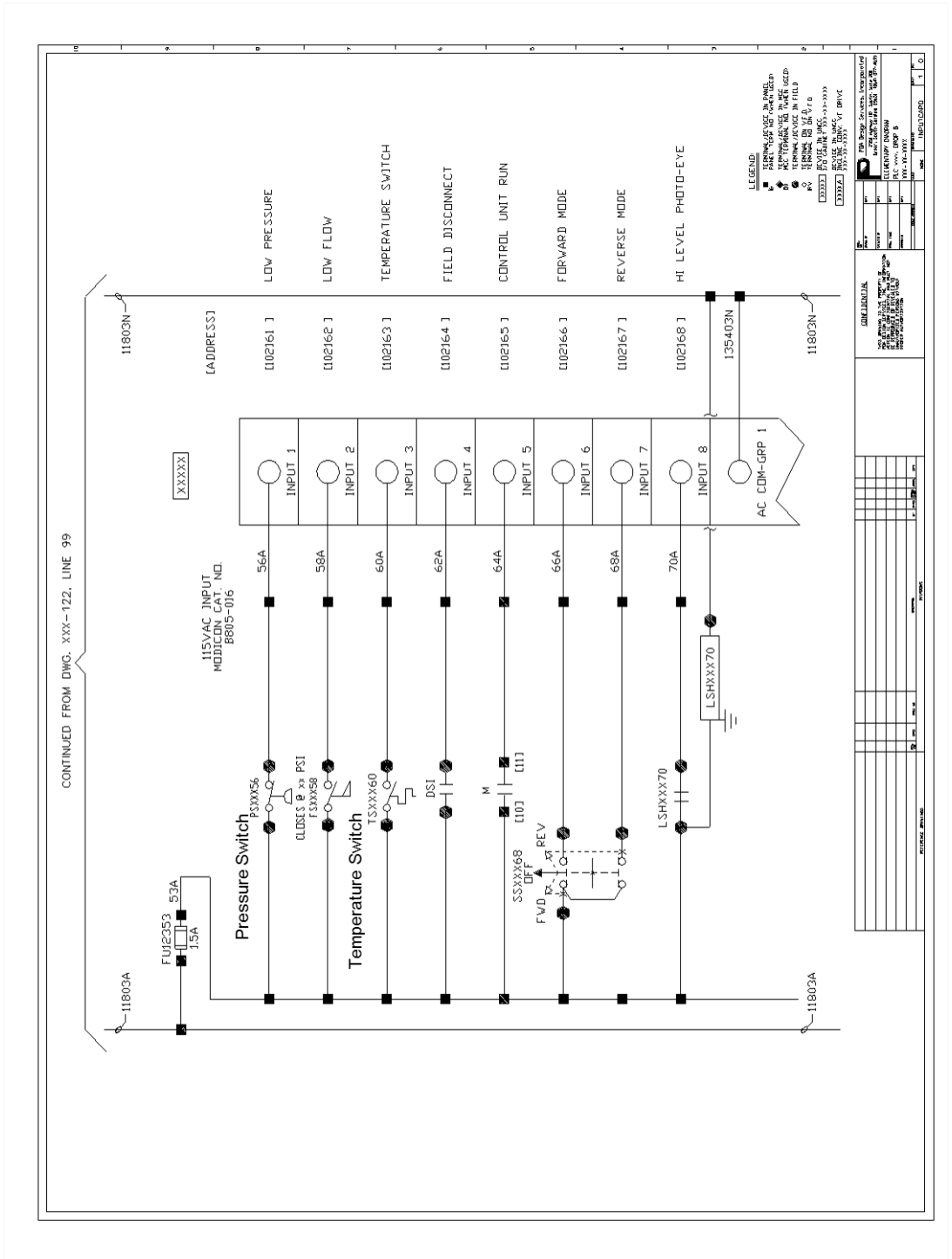

Figure 2.7 – Input Control Drawing

Output Control Diagram

As described earlier, the 115 VAC Modicon output module, shown in Figure 2.8, serves as an interface between the PLC and the control devices in the field. Let's continue our analysis of the hypothetical scenario surrounding the loss of pressure in a vessel; with the focus, this time, on specific outputs associated with the proper response to the anomaly described above. Assume that the PLC's response, to the anomaly described above, involves some actions that yield instantaneous results and some that will require a finite amount of time to implement. Actions that the PLC based control system must initiate and execute, immediately, are as follows:

- 1) Energize the reserve tank solenoid valve to boost the vessel pressure to a certain level.
- 2) Turn ON the alarm horn.
- 3) Turn ON the "Critical/Low Pressure Alarm light.
- 4) Turn ON the pump motor starter.

In order to energize the reserve tank solenoid valve to boost the vessel pressure, the PLC CPU must change the logic level at Output #5 from a "0" to a "1." The output module transduces the "1" to a 120 V output at the terminal for output #1. This 120 V control voltage propagates to the solenoid through the 1.5A short circuit protection fuse FUxxx14 and turns on the solenoid. The solenoid opens the reserve tank valve and begins to pressurize the vessel.

In order to implement full restoration of pressure in the vessel, the PLC CPU must change the logic level at Output #1 from a "0" to a "1." As a result, the 120 V control voltage propagates to the Pump Motor Starter coil through the 1.5A short circuit protection fuse FUxxx06 and a normally open safety interlock contact. The safety interlock is assumed to be met, so, this safety interlock contact should be closed. The 120 VAC, therefore, arrives at the pump motor starter, "M," energizes it, and starts the 3-hp motor, shown on Figure 2.8.

At the same instant, the CPU changes the state of Output #7 from "0" to a "1," thus sending 120 V to the alarm horn through another 1.5A fuse. The horn continues to annunciate the critical alarm condition, audibly, until the CPU has received verification of re-pressurization of the vessel via Input #1 or the alarm is acknowledged and silenced through a horn silence circuit on the

input side of the control system. Note that the horn-acknowledge and silence button is not shown on input control drawing in Figure 2.7.

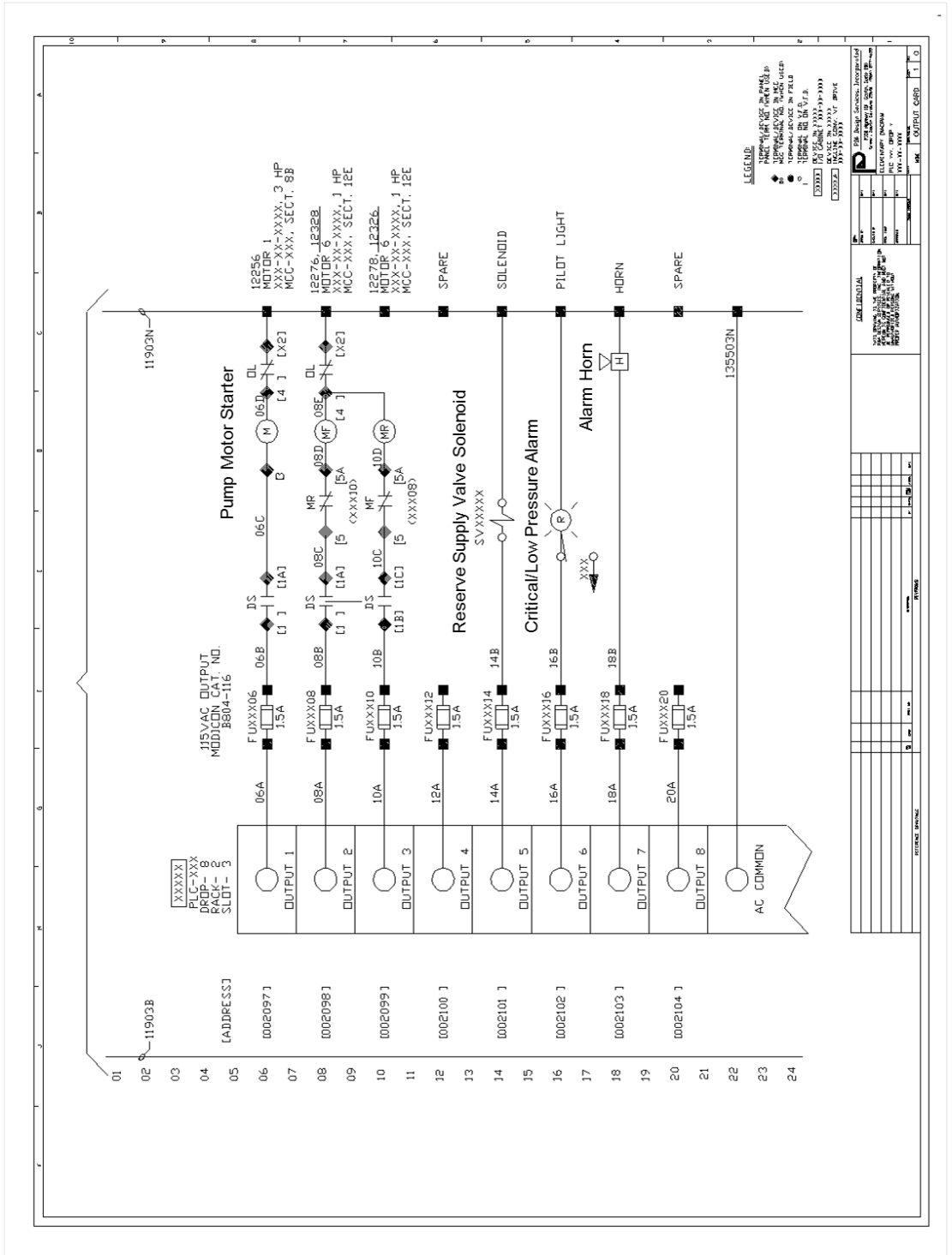

Figure 2.8 – PLC output module based control drawing.

In addition to turning ON Output #7, the CPU changes the logic state of Output #6 from a “0” to a “1,” thus sending 120 V to an alarm light via 1.5A fuse FUxxx16. The alarm light turns on and stays on until the CPU has received verification of re-pressurization of the vessel via Input #1.

Relay Ladder Logic

An introduction to control circuits and control systems would be incomplete without some explanation and illustration of PLC programming method. Even though the brain of a PLC, like a PC (Personal Computers), consists of single or multiple microprocessors, unlike a PC it does not operate off a “Windows ®” or Microsoft Office based software systems. PLC operation is based on proprietary software, provided by the PLC manufacturer. On the other hand, the PLC *programming* software, nowadays, is “Windows ®” based. The programming software allows control engineers and technicians to program the operation of PLC’s in form of a diagrammatic programming language called *Relay Ladder Logic*. This programming language emulates the “pre-PLC” era, electromechanical relay, counter and timer based control logic, in symbolic form. Of course, the symbols and associated functions are represented as “virtual” symbols and logical functions that are used to implement functional specifications of the overall control system. In the pre-PLC era, these electromechanical relay, timer and counter based functions had limited reliability, lacked speed, resolution, accuracy, flexibility, versatility and occupied a great deal of control cabinet or control room space. PLC manufacturers, such as Rockwell ® provide training classes for control engineers and technicians, on PLC programming and installation, at local or regional offices.

A basic, relay ladder logic based, program example is shown in Figure 2.9. Brief excerpts of a comprehensive relay ladder logic program for a control system are shown in figures 2.9 and 2.10. These excerpts are, actually, screen captures or “print screens” of the PLC program as viewed by a PLC programmer for program creation, program modification or troubleshooting purposes. These excerpts represent a specific example of an RSLogix5000 program for an Allen Bradley Control Logix Programmable Controller.

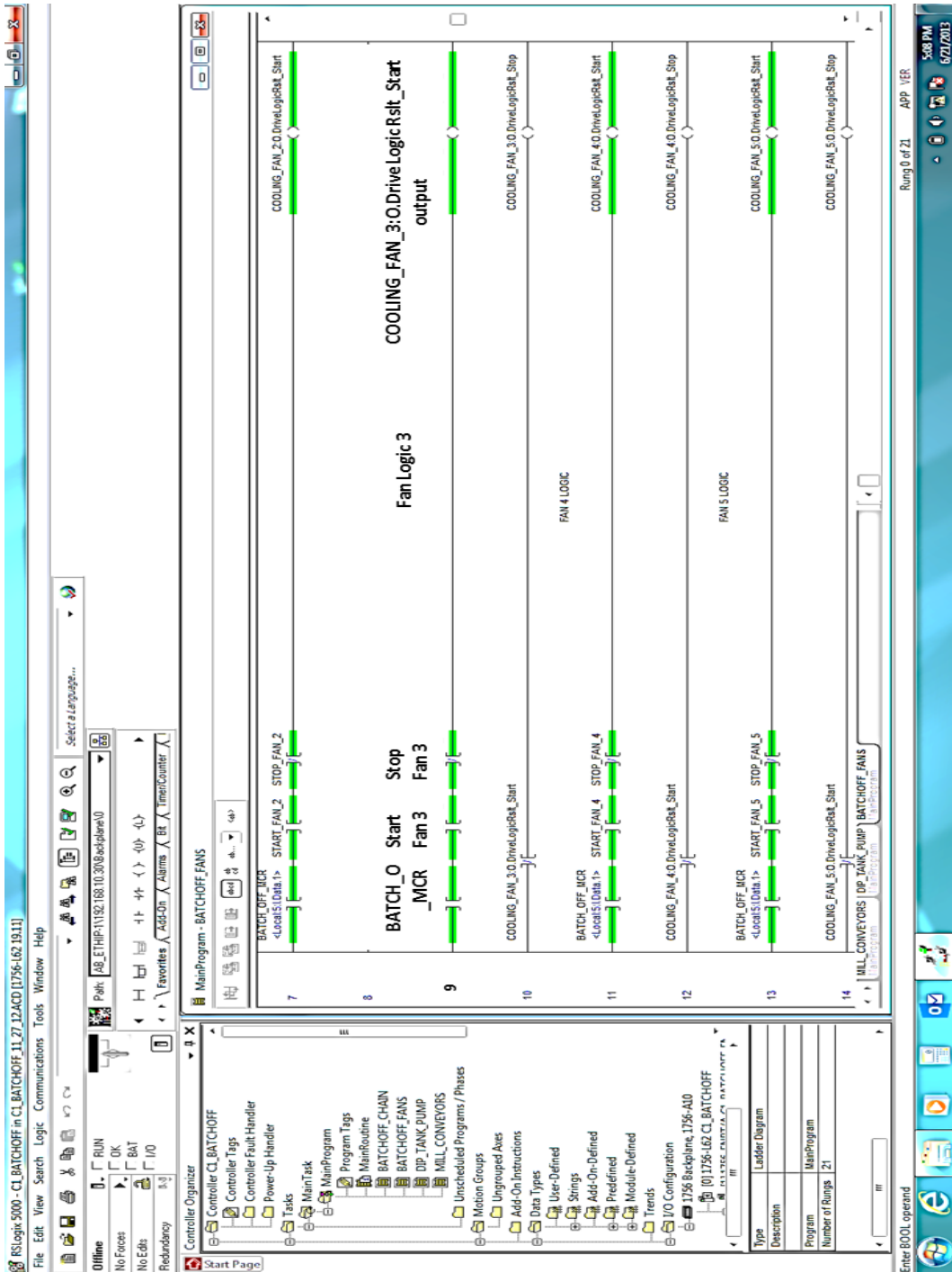

Figure 2.9 – PLC Relay Ladder Logic Programming Example – Cooling Fan Control Logic.

Fan Start and Stop Program Segment: Note that, at first glance, *this* page of the overall program for the control system resembles a typical Windows ® based application program. However, a closer inspection reveals that - unlike computer programming languages like COBOL, Basic, C, C+, etc. - this is a diagrammatic logic code, wherein, program or algorithm is premised on symbols that appear as coils and contacts of relays, timers, counters, etc. As visible on the left side of the relay ladder program, there are seven tiers, lines or “rungs” depicted on this page of the program, ranging from rung #7 to rung #14. The logic symbols in each rung represent *inputs* and *outputs*. See segment 8 for descriptions and illustration of typical PLC inputs and outputs. These inputs and outputs, in a typical PLC program, can be “*internal*” or “*external*” inputs. External inputs (**discrete**) are inputs that represent “tangible” or physical switches and contacts in the field. In other words, these inputs emanate from devices and equipment that are “peripheral” to the PLC. On program segment depicted in Figure 2.9, the logic elements, input and output symbols can be categorized as follows:

Batch MCR: Batch control system master control relay contact. This contact is “normally open,” but shown closed - at the time the program was viewed - through high lighting (darker shading) of the contact.

Start Fan 3: This symbol or element represents the normally open contact of the START switch for Fan #3. Even though this is a “normally open” contact “--| |--,” it is shown *closed* - at the time the program was viewed - through high lighting (darker shading) of the contact.

Stop Fan 3: This symbol or element represents the normally closed contact belonging to the STOP switch for Fan #3. This is a “normally closed” contact “--|/|--”(look for the “/” within the parallel lines) and it is shown *closed* (True) - at the time the program was viewed - through high lighting (darker shading) of the contact. In other words, the STOP switch is not depressed at this time.

Cooling Fan # 3 Dr Start: The coil symbol “—()—,” typically, represents an output. When this output is energized or “**True**,” it actually turns ON an output, such as those outputs we considered in the review of PLC Output Controls Drawing in Figure 2.8. In this case, this output is connected to a VFD, Variable Frequency Drive.

Note that all elements in Rung #9 are highlighted, meaning, they were conducting current, ON, or True, at the time the snap shot of the program was taken. Note that when elements are *closed* or passing current, their status is said to be “*True*.” When elements are not energized, not activated, their status is said to be “*False*.” The current status of Rung #9 can be interpreted as follows:

At the time this snapshot of the logic was taken, **BATCH_OFF_MCR** input was **True**, closed or High, the **START_FAN_3** bit (logical representation of input emanating from **Fan #3** start switch) is **True**, and the **STOP_FAN_3** bit (logical representation of input emanating from Fan #3 stop switch) is **false** then the **COOLING_FAN_3:O. DriveLogicRsIt Start** output (same as Cooling Fan # 3 Dr Start output) will go high or **True**. This output is directly connected via the software to the Allen Bradley ® (PowerFlex 70) Variable Frequency Drive (VFD). This is accomplished through an Ethernet connection and will cause the motor connected to the VFD to start. In this case there are seven fans that are used to cool freshly made rubber so that it can be used in the next process.

Example 2.2.

Consider the PLC relay ladder logic program in Figure 2.9 and answer the following questions:

- a) What would happen to the “run” signal going to the VFD if MCR, Master Control Relay, drops out or de-energizes?
- b) How does Rung #10 respond to the energization (becoming True) of **COOLING_FAN_3:O. DriveLogicRsIt Start** output?

(a) Answer: If the MCR, master control relay, for the system drops out or de-energizes, the continuity of rung #9 would break. This will result in de-energization of **COOLING_FAN_3:O. DriveLogicRsIt Start** output to the VFD, and Cooling Fan #3 will **stop**.

(b) Answer: Upon inspection of Rung #10, we see that a normally closed contact belonging to output “**COOLING_FAN_3:O. DriveLogicRsIt Start**” is in series in Rung #10. This normally closed contact opens when **COOLING_FAN_3:O. DriveLogicRsIt Start** output is energized. That is the reason why both elements in this rung are shown de-energized (no shading or highlighting). Note that the output of this rung is labeled as

COOLING_FAN_3:O. DriveLogicRslt Stop. This implies that when **COOLING_FAN_3:O. DriveLogicRslt Start** output is turned ON, the **STOP** signal to the Cooling Fan VFD is disabled through the normally closed contact of **COOLING_FAN_3:O.DriveLogicRslt Start** “coil” in Rung #10. In essence, Rung #10 serves as an interlock to ensure that the STOP command to Cooling Fan #3 is disabled when Cooling Fan #3 START bit is ON.

Timer Based Starting Control Logic: The PLC control program examined in this section is shown in Figure 2.10. The logic elements, input and output symbols, employed in this section of the overall PLC program are shown on Rung 11, in Figure 2.10. The logic represented in this rung is more complex than the logic associated with Rung #9 on Figure 2.8. The essence of this program rung is as follows:

If all of the requirements, conditions, or bits for the Examine if ON (labeled as XIC, Examine if Closed) and Examine if Off (XIO), in Rung 11, are **True** then Timer P105.TD_CASCADE_START will start timing. Notice the rectangular block on the right side of this rung. This block represents the timer. The timer setting is annotated as 2500. The set-point of 2500, in this case, implies 2500 milliseconds. In other words, the timer will time for 2.5 seconds before energizing the output. When 2.5 seconds expire, timer output labeled as P105.TD_CASCADE_START.DN becomes **True**, and P105_CONVEYOR_CMD will turn ON starting P105 conveyor in this simple material handling conveyor system application.

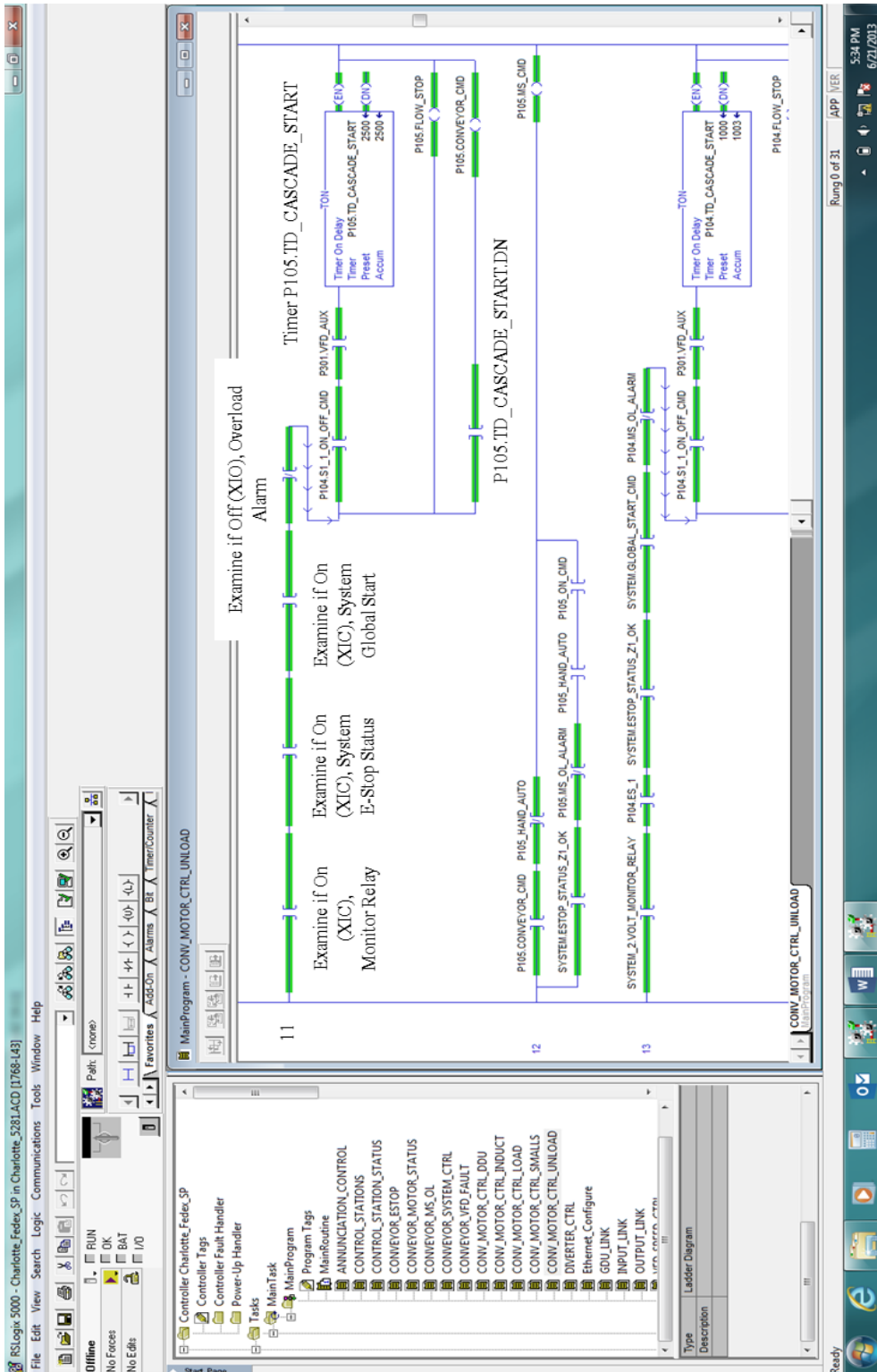

Figure 2.10 – PLC Relay Ladder Logic Programming Example – Cascade start timer.

Example 2.2

Consider the logic associated with Timer P105.TD in Rung # 11 of the PLC relay ladder logic program shown in Figure 2.10 and answer the following questions:

- a) Which “register” of field on Rung #11 represents the *time elapsed* while the timer is timing?
- b) What is the status of the timer? How many seconds remain on the clock before the timer times out?
- c) What is the function of Rung #11 branch consisting of the “P105.TD_CASCADE_START.DN” bit and the “P105 Conveyor _CMD” coil?

(a) Answer: As we examine the right side of Timer P105.TD in Rung # 11, we see the register or field labeled “Preset 2500.” This register holds the timer preset time of 2500 milliseconds. The register directly below the Preset register is labeled “Accum 2500.” This field can be interpreted as: Accumulated or elapsed time = 2500 milliseconds, or 2.5 seconds.

(b) Answer: As observed in part (a), the accumulated or elapsed time = 2500 milliseconds. Since the Accumulated or elapsed time is equal to the Preset time, the timer has timed out, and “0” milliseconds remain.

(c) Answer: As we examine the right side of Timer P105.TD in Rung # 11, and observe the branch with two elements, the “P105.TD_CASCADE_START. DN” bit and the “P105 Conveyor _CMD” coil, we note the fact that P105 Conveyor is commanded to turn ON when the P105.TD_CASCADE_START. DN contact or bit is closed, or True. In other words, after the accumulated time reaches the preset time of 2500 milliseconds, the “**Done**” coil labeled as —(DN)—, turns ON or becomes **True**. This results in the closure (or conversion to **True** state) of the timer **Done** bit: “--| |--“ 105.TD_CASCADE_START. DN, and with the three XIC and one XIO conditions satisfied (**True**), the P105 Conveyor _CMD” coil is energized to turn on P105 Conveyor.

Self-assessment Problems and Questions – Segment 2

1. Answer the following questions pertaining to the branch circuit shown in the schematic diagram below:

- What is the maximum voltage the power distribution system for this branch circuit rated for?
- How many wires and phases is the power distribution system for this motor branch circuit rated for?
- What would be the proper rating for the branch circuit disconnect switch?
- What should the solid-state overload device be set for at commissioning of this branch circuit?

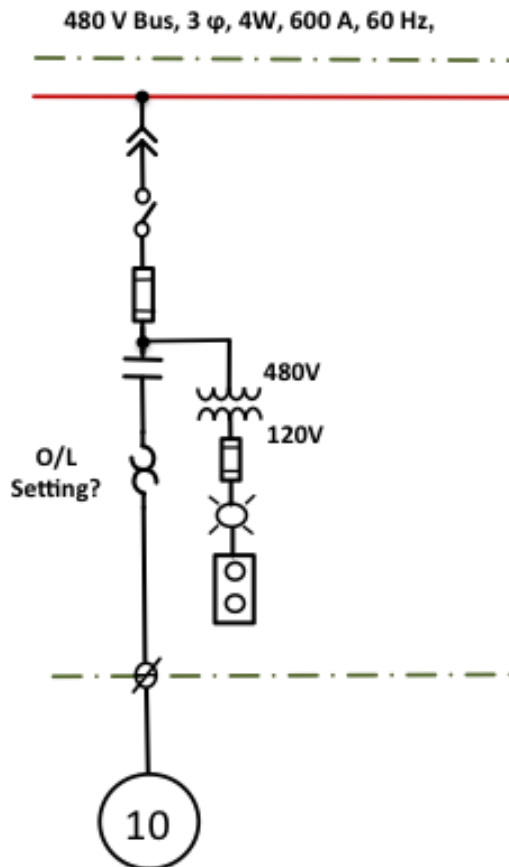

2. Determine the sizes/specifications of the following components in the branch circuit shown below using the Bus[®] Table and information included in the questions:

- (a) Conductor size.
- (b) Conduit size.
- (c) Overload setting based on the 115% NEC[®] stipulation.
- (d) Disconnect switch size, safety and fusible.

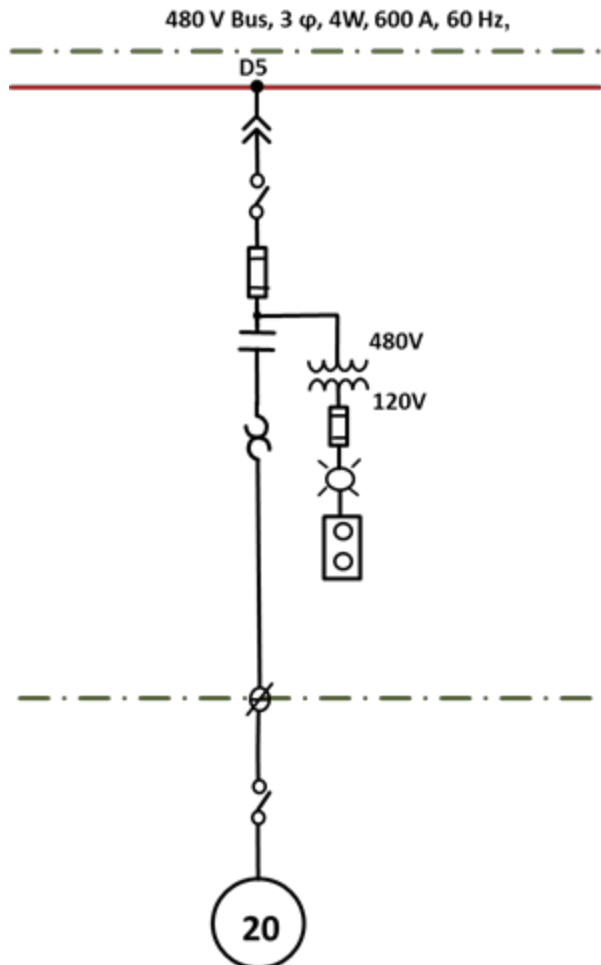

3. Consider the wiring diagram for the 75-hp motor shown in Figure 2.6 and answer the following questions based on the control logic explained in this segment:

- a) What would be the likely outcome if the START switch is depressed while the motor is operating?

- b) What would be the outcome if START and STOP switches are depressed simultaneously?
- c) What would be the likely outcome if the main disconnect switch for the MCC is opened?
- d) Can the motor be stopped if the motor starter latching contact “welds” shut due to overheating?

4. Consider the logic associated with Timer P105.TD in Rung # 11 of the PLC relay ladder logic program shown in Figure 2.10 and answer the following questions:

- a) What would be status of the timer **Done** bit: “--| |--“ 105.TD_ CASCADE_ START. DN, if the XIC System E-Stop bit turns “**False**” 1 second after Timer P105.TD in Rung # 11 is turned on?
- b) Would the “P105 Conveyor_CMD” bit – commanding P105 Conveyor to turn ON be **True** if and when the system E-Stop switch is engaged/pressed?

Segment 3

Electrical Power Rate Schedules and Electrical Energy Cost Savings Opportunities

Introduction

The purpose of this brief segment is to introduce the reader to three pronged approach associated with comprehensive electricity cost reduction. This segment allows readers an opportunity to enhance their knowledge about various electrical power rates or contracts. Better awareness of electrical energy cost structure allows a utilities engineer, plant engineer, or a facilities manager an opportunity to make calculated and informed decisions associated with electrical energy cost minimization. We will also explore some electrical cost reduction ideas. We will explore the concepts of EPC and ESCO's as a means for pursuing electrical energy intensity improvement projects with little or no capital investment.

Three Pronged Approach to Electrical Energy Cost Reduction¹

Most energy programs - adopted for residential, commercial, or industrial settings - focus, mainly, on *energy conservation*. However, in order to develop a more comprehensive and complete energy program, one should view an electrical energy intensity improvement program as a three pronged approach. Those three prongs or pillars are as follows:

- I. **Energy Conservation:** This facet consists of the application of high efficiency electrical equipment, i.e. premium efficiency electric motors, energy efficient lighting systems, etc.
- II. **The Supply Side:** Exploration, evaluation and application of local electrical power generating systems that are cost competitive with the grid.
- III. **Energy Cost Rate:** This approach focuses, primarily, on exploration and financial evaluation of electrical power schedules and contracts that offer the lowest overall cost rates for commercial and industrial applications.

¹ Finance and Accounting for Energy Engineers by S. Bobby Rauf

Electric Utility Rate Schedules¹:

Measurement, verification and computation of utility bills are key elements in understanding, planning for and managing the consumption of various utilities. Conservation of utilities is an essential and strategic component of overall utility cost reduction effort. Its primary impact is through enhancement of utility productivity; or, in the strict energy realm, through maximization of energy productivity. The other vital determinants of the overall cost of utilities are contract and rate structure. In a given billing month, once the utility usage has been recorded, it must be processed using the rate schedule or structure the contract calls for.

The thrust of our discussion, in this segment, will entail introduction of various rate schedules and the impact of major rate schedules on the composition of the electric bill in the industrial and residential realm. The residential rate structures and computation methods are relatively straightforward. Consequently, our discussion on residential electric bills will be brief. Some of the contract categories and rate schedules are as follows:

- Industrial
- Commercial
- Residential
- Municipal or Co-op's
- OPT, or Time of the Day
- HP, or Hourly Pricing
- Interruptible

Most utility companies, around the United States, offer rate schedules similar to the ones stated above. However, in many instances the names of the rate schedules may vary from one utility to another. Despite the apparent semantic differences among rate schedules offered by various utilities, the cost components, cost tiers and rate application mechanisms are similar. The essence and format of electrical rate schedules are being introduced in this text using Duke Energy[®] Company as an example.

¹ Finance and Accounting for Energy Engineers by S. Bobby Rauf

Duke[®] is one the largest electric power holding company in the United States, supplying and delivering energy to approximately 7.2 million U.S. customers. Duke[®] has approximately 57,700 megawatts of electric generating capacity in the Carolinas, the Midwest and Florida. Duke[®] is headquartered in Charlotte. Duke’s[®] service area consists of approximately 104,000 square miles in the Southeast and Midwest.

Details on Duke[®] Energy electric power rates are available at the following Duke Energy[®] Website:

<http://www.duke-energy.com/rates/north-carolina.asp>

Some of the rates schedules offered by Duke[®] are listed in Table 3.1 below, with the more common ones highlighted.

Rate Code	Description
RS	Residential Service
RE	Residential Service, Electric Water Heating and Space Conditioning
ES	Residential Service, Energy Star
RT	Residential Service, Time-of-Use
WC	Residential Service, Water Heating, Controlled/Submetered
SGS	Small General Service
OPT-G	Optional Power Service, Time of Use General Service
BC	General Service, Building Construction Service
LGS	Large General Service
FL	General Service, Floodlighting Service
OL	General Service, Outdoor Lighting Service
GL	Government Lighting Service
PL	General Service, Street and Public Lighting Service

NL	Nonstandard Lighting Service
TS	General Service, Traffic Signal Service
I	Industrial Service
OPT-E	Optional Power Service, time of Use, Energy-Only (Pilot)
OPT-H	Optional Power Service, Time of Use, General Service, High Load Factor
OPT-I	Optional Power Service, Time of Use, Industrial Services
HP	Hourly Pricing for Incremental Load
PG	Parallel Generation
REPS	Renewable Energy Portfolio Standard Rider
PM	Power Manager Load Control Service Rider
NM	Net Metering Rider (NM)
SCG	Small Customer Generator Rider (SCG)
IS	Interruptible Power Service Rider
SG	Standby Generator Control Rider
EC	Economic Development Rider
ER	Economic Redevelopment Rider
PSC	Power Share Call Option
PP-N	Purchased Power Non-Hydroelectric
PP-H	Purchased Power Hydroelectric

Table 3.1: Some Rate schedules offered by Duke[®] Energy

Three of the most common schedules are explained in more detail below through excerpts from the Duke Energy[®] website. These schedules are also more pertinent to the topics introduced in this text. The reader is advised to regard the following excerpted rate schedule information as *reference information* intended to *introduce* the reader to typical electrical billing terminology and general format of the electrical power bills in the residential and industrial sectors. The rates quantified in the discussion that follows represent a “snapshot” at the time this text was authored, and only the current prevailing rates should be used in the practice of engineering, energy or facilities management.

Schedule RS (NC)

The RS stands for Residential Service. This specifics of this schedule, as published by Duke ®, apply to the State of North Carolina, only.

This schedule and associated rates are available only to residential customers in residences, condominiums, mobile homes, or individually-metered apartments which provide independent and permanent facilities complete for living, sleeping, eating, cooking, and sanitation.

Type, or specification, of (RS) service: Under this schedule, Duke Energy ®, agrees to furnish 60 Hertz service through one meter, at one delivery point, at one of the following approximate voltages, where available:

- Single-phase, 120/240 volts
- Or, 3-phase, 208Y/120 volts
- Or other available voltages at the Company's (Duke's ®) option.
- Motors in excess of 2 H. P., frequently started, or arranged for automatic control, must be of a type to take the minimum starting current and must be equipped with controlling devices approved by the Company (Duke ®).

Where three-phase and single-phase service is supplied through the same meter, it will be billed in accordance with the rates listed below. Where three-phase service is supplied through a separate meter, it will be billed on the applicable **General Service schedule**:

I. Basic Facilities Charge per month: **\$ 9.90**

II. Energy Charges

- For the billing months of July – October, for all kWh used per month:
9.2896¢ per kWh*
- For the billing months of November – June, for all kWh used per month:
9.2896¢ per kWh*.

Note that the two rates stated above may not always be the same.

* For complete details and exemptions, the reader is encouraged to visit Duke Energy ® rate schedule website, referenced above.

Schedule OPT-I (NC)

This rate schedule represents an *optional power industrial service* that is based on time of use. Therefore, it is often referred to as **Time of Use Industrial Service**.

This rate schedule, offered by Duke Energy ®, as specified in this text, is available in North Carolina Only. Furthermore, this rate schedule is available only to establishments classified as “Manufacturing Industries” by the Standard Industrial Classification Manual published by the United States Government, and where more than 50% of the electric energy consumption of such establishment is used for its *manufacturing processes*.

The specifications of this rate schedule or service, as stipulated by Duke Energy ®, are as follows:

- The Company (Duke Energy ®) will furnish 60 Hertz service through one meter, at one delivery point, at one of the following approximate voltages, where available:
 - Single-phase, 120/240 volts, 120/208 volts, 240/480 volts or other available single-phase voltages at the company’s option; or
 - 3-phase, 208Y/120 volts, 460Y/265 volts, 480Y/277 volts; or
 - 3-phase, 3-wire, 240, 460, 480, 575, or 2300 volts; or
 - 3-phase, 4160Y/2400, 12470Y/7200, or 24940Y/14400 volts
- Motors of less than 5 H.P. may be single-phase. All motors of more than 5 H.P. must be equipped with starting compensators. The Company (Duke Energy ®) reserves the right, when in its opinion the installation would not be detrimental to the service of the Company, to permit other types of motors.

Rates Under OPT –I Schedule

As evident below, due to the fact that this rate schedule is a function of time and seasons, rate structure under the OPT-I schedule is multi-dimensional and more complex. The rate (or charge) components of an OPT-I based electric power bill, at the time this text was authored, were as shown in Table 3.2.

RATE: I.	Basic Facilities Charge per month	\$39.79
II. Demand Charge	Summer Months	Winter Months
A. On-Peak Demand Charge	June 1 – September 30	October 1 – May 31
For the first 2000 kW of Billing Demand per month, per kW	\$14.0767	\$8.2981
For the next 3000 kW of Billing Demand per month, per kW	\$12.8972	\$7.1075
For all over 5000 kW of Billing Demand per month, per kW	\$11.7067	\$5.9064
B. Economy Demand Charge	\$1.1448	\$1.1448

III. Energy Charges	All Months
A. All On-Peak Energy Per Month, Per kWh	5.7847¢
B. All Off-Peak Energy, Per Month, Per kWh	3.4734¢

Table 3.2: Time of Use, OPT-I Rate Schedule offered by Duke ® Energy

On-Peak and Off-Peak Hours, for Schedule OPT-I, are classified as follows:

On-Peak Hours:

Summer Months

June 1 – September 30, Monday – Friday

On-Peak Period Hours

1:00 p.m. – 9:00 p.m.

Winter Months

October 1 – May 31, Monday – Friday

On-Peak Period Hours

6:00 a.m. – 1:00 p.m.

Off-Peak Hours:

- All weekday hours not included under On-Peak hours, and all Saturday and Sunday hours.

- All hours for the following holidays:
 - New Year’s Day, Memorial Day, Good Friday, Independence Day, Labor Day, Thanksgiving Day, Day after Thanksgiving, and Christmas Day.

Determination of Billing Demand

A. The On-Peak Billing Demand each month shall be the largest of the following:

1. The maximum integrated thirty-minute demand during the applicable summer or winter on-peak period during the month for which the bill is rendered.

2. Fifty percent (50%) of the Contract Demand (or 50% of the On-Peak Contract Demand if such is specified in the contract)

3. 15 kilowatts (kW)

B. Economy Demand: To determine the Economy Demand, the larger of

1. The maximum integrated thirty-minute demand during the month for which the bill is rendered; or
2. 50% of the Contract Demand shall be compared to the On-Peak Billing Demand as determined in A. above.

If the demand determined by the larger of B.1 and B.2 above exceeds the On-Peak Billing Demand, the difference shall be the Economy Demand.

Power Factor Correction

When the average monthly power factor of the Customer's power requirements is *less than 85 percent*, the Company may correct the integrated demand in kilowatts for that month by multiplying by *85 percent* and dividing by the average power factor in percent for that month.

Hourly Pricing Option/Schedule

If your business is expecting incremental loads and has the ability to manage consumption patterns on a day ahead, hourly basis, Duke Energy ® can offer electric energy cost savings through rate schedule HP, also referred to as *Hourly Pricing*. This opportunity is available to customers who have the ability to be responsive to fluctuations in hourly prices (use more energy when prices are low, use less energy when prices are high).

The HP schedule is available to non-residential establishments with a minimum contract demand of 1000 kW who qualify for service under the Duke Energy ® rate schedules LGS, I, OPT-G, OPT-H, OPT-I, or PG, at the Company's (Duke Energy ®) option on a voluntary basis. The maximum number of customers on the system to be served under this schedule is one hundred fifty (150). Service under this Schedule is available to contracting customer in a single enterprise, located entirely on a single, contiguous, premises.

Areas of Opportunity for Electrical Energy Cost Savings

There are several areas of potential cost savings available to electrical power consumers, beyond the ones discussed in this text, so far. The reader is encouraged to see organized and comprehensive approach to energy cost reduction, supported by illustrative case studies, in *Finance and Accounting for Energy Engineers, By S. Bobby Rauf*. Some areas of opportunity, related specifically to electrical rate schedules, are listed below:

Schedule or Rider SG, On-Site Generation

This program is designed to offer large industrial or commercial consumers an opportunity take advantage of on-site emergency power generation assets they already own. Most emergency power generators have to be tested, under load, periodically, for predictive maintenance, preventive maintenance and personnel training purposes. Why not get compensated or credited for this routine, but necessary, exercise by the power company? That is where Schedule or Rider SG offers the larger consumers an opportunity to do so.

Therefore, if a large consumer owns emergency standby generators and can make their capacity available for use by Duke Energy ® during times of system emergencies, monthly credits are offered through rate rider SG.

Schedule or Rider IS, Interruptible Power Service

The interruptible power service schedule, IS, is available for nonresidential customers receiving concurrent service from the Company (Duke Energy ®) on Schedules LGS, I, HP, OPT-G, OPT-H or OPT-I, served under continually effectively agreements for this Rider made prior February 26, 2009. Under this schedule, the customer agrees, at the Company's (Duke Energy's ®) request, to reduce and maintain his load at a level specified in the individual contract. The Company's request to interrupt service may be initiated at any time the Company has capacity problems.

Contracts for interruptible power service are accepted by Duke Energy® on the basis of successive contracts, and each contract must specify an interruptible, integrated demand of not more than 50,000 KW to be subject to these provisions. The Company can limit the acceptance of contracts to a total of 1,100,000 KW of Interruptible Contract Demand on all non-residential schedules on the total system.

Duke Energy[®] reserves the right to test the provisions of this Rider once per year if there has not been an occasion during the previous 12 months when the Company requested an interruption. Duke Energy[®] gives advance notice of any test to customers served under this Rider. In return for participation in this schedule, Duke issues credits to the participating customers based on a specific formula that can be reviewed at Duke Energy[®] Website.

Tips on Utility Rate Schedules and Contracts

Its, ultimately, the consumer's responsibility to maintain vigilance and awareness of opportunities and incentives available through the power company that serves the region. The following tips can prove to be useful to the consumer for minimizing the *cost* of electrical energy:

1. Electric Utility Company is not obligated to notify facilities about availability of more favorable rates or “schedules.” Some utility companies, for example, Duke Energy[®], assign Account Managers to certain segments of their market. In order to maximize the utility of the consumer's relationship with the assigned Account Manager, the consumer's representative, namely the energy or utilities engineer, must note the following:
 - Utility company Account Managers will, at times, advise their larger accounts of favorable rate schedules as the customers' demand and usage changes. However, it is good practice to explore suitable contract alternatives, when some of the following changes are experienced in load characteristics and profile:
 - **Addition or removal of loads** that constitute a substantial percentage of facility's overall load.
 - **Addition of highly reactive loads**, i .e large motors, transformers. This might impact the facility's overall power factor and energy consumption.

2. Look for newfound **flexibility in load schedules**. For example “Off-Peak” unloading of rail cars, in industries where mass transport of raw materials is required.
3. Look for addition of **onsite generation**; Standby or Cogeneration assets.
4. Be vigilant of any change in facility’s operation constraints. For instance:
 - Could the facility tolerate power interruption, with some advance notice?
 - Could facility participate in, on-line, diesel generator testing.
5. **Renewable Energy Portfolio Standard (REPS) Adjustment:**
The monthly bill shall include a REPS Adjustment based upon the revenue classification:

Commercial/Governmental Classification - **\$3.22/month**

Industrial/Public Authority Classification - **\$32.20/month**

Upon written request, only one REPS Adjustment shall apply to each premise serving the same customer for all accounts of the same revenue classification. If a customer has accounts which serve in an auxiliary role to a main account on the same premise, no REPS charge should apply to the auxiliary accounts regardless of their revenue classification (see Annual Billing Adjustments Rider BA).

6. **Transformation Discounts:** When Customer owns the step-down transformation and all other facilities beyond the transformation which Company (Duke Energy ®) would normally own, except Company's metering equipment, the charge per kW of on-peak Billing Demand will be reduced as follows:

Transmission Service: \$0.75/kW

Distribution Service: \$0.5/kW

For customer to qualify for the Transmission Service Transformation Discount, customer must own the step-down transformation and all other facilities beyond the transformation which Company (Duke Energy ®) would normally own, except Company's metering equipment, necessary to take service at the voltage of the 69 kV, 115 kV, or 230 kV transmission line from which Customer received service.

Energy Performance Contracting and ESCO Opportunities¹

EPC, Energy Performance Contracting, is a service vehicle for provision of energy conservation or energy productivity enhancement services. In most cases, EPC type contracts and projects involve turnkey service. Turnkey service is defined as a comprehensive service provided by a vendor or contractor that begins with definition and scope of an energy project and ends with project start up, commissioning and subsequent verification of energy savings. Projects covered by EPC range from simple energy conservation efforts such as replacement of inefficient lighting systems to more complex projects that address the supply side of the energy equation through renewable energy systems.

While EPC and ESCO alternatives are often adopted for substantial energy conservation or renewable energy projects, initiatives that leverage lower cost power contracts can be included in the overall energy project portfolio. EPC projects and contracts often include guarantees that the savings produced by a project will be sufficient to finance the full cost of the project.

The guarantee to fund the project through the savings generated by the project is what distinguishes **EPC** projects from **non-EPC**, or owner funded energy projects. Even though it appears counter intuitive, often EPC projects are not limited to energy conservation or energy capacity enhancement projects, instead, the breadth of their scope includes water conservation, sustainable materials and operations.

ESCO stands for Energy Service Company. One way to understand the relationship and distinction between EPC and ESCOs is to think of EPC, Energy Performance Contracting, as a *process* and the ESCOs as *entities that implement the EPC process*.

¹ Finance and Accounting for Energy Engineers by S. Bobby Rauf

ESCOs can provide a full range of services required to complete an energy project. Such services, often, include the following or a combination, thereof:

- Energy audit
- Design engineering
- Construction management and supervision
- Facilitation or provision of project financing
- Start-up and commissioning
- Operations and maintenance
- Monitoring and verification of energy savings

Historically, the inception of EPC could be traced as far back as the early eighties. In the pre-1985 era, ESCOs were established, as a part of the DSM, Demand Side Management, efforts to provide personnel and equipment resources to the utilities as they strived to meet the energy conservation mandates imposed by federal and state governments.

From the mid 1980's through 2003, ESCOs, and EPC industry as a whole, have seen substantial ebb and flow in growth, acceptability and revenue. Over this period, some of the ESCOs have transformed and some have grown either organically or accretively, through consolidation. This evolution within the EPC domain was influenced, favorably, by the state and federal governments. The successes of the EPC industry, in the 1994 – 2002 period could, to a certain extent, be attributed, to studies by LBNL, Lawrence Berkley National Laboratory, and NAESCO, National Association of Energy Service Companies, that highlighted the EPC successes and encouraged the state and federal governments to promote EPC. Another important event that could be credited for EPC growth and successes in the 1994 – 2002 period was the formulation and implementation of the IPMVP, or International Performance Measurement and Verification Protocol. The IPMVP provided standard methods for documenting project savings and provide commercial lenders the confidence to finance EPC projects.

As plausible, the EPC industry was impacted unfavorably by the ENRON debacle, as ENRON was a significant player in the ESCO market. The ENRON collapse coupled with the uncertainty about the deregulation of the electric utility industry impeded the growth of EPC in the 2002 to 2004 period.

The 2004 – 2006 period showed 20% growth in the EPC industry with comparable projected growth trend. The 20% growth, and subsequent upward trend can be attributed to volatility in the energy market and the increasing energy prices. Other contributors to the heightened interest in the EPC are state and federal mandates, inadequate capital and maintenance budgets for federal and state facilities. Growing awareness of the greenhouse gas emissions and realization of the fact that large scale, sustained, remediation is needed in this regard has made EPC more attractive at local, state and federal levels, and in the private sector.

While ESCOs, in response to customer requests, are constantly adding new measures and services to their project portfolios, electrical and non-electrical, they are not to be construed as stewards for technological research, development and marketing in the energy domain. ESCOs and their clients tend to be fairly conservative and risk averse in selection of technologies for projects. Due to the fact that the cost of most ESCO projects are paid from energy savings, often secured with financial guarantees, ESCOs and their clients tend to lean in favor of proven technologies.

Energy Performance Contracting involves distinct skills and areas of expertise in the following two areas:

- Energy procurement
- Commercial law.

Both of these disciplines involve risk management, risk allocation, isolating benefits, and option analysis. The following list could serve as a checklist for energy managers, utilities engineers and facilities managers as they consider EPC and ESCO's in formulation of the energy program strategy:

- ✓ EPC, or Energy Performance Contracting is *one* way to finance and implement energy conservation projects.
- ✓ Remuneration sought by the EPC's is typically included in the overall cost of the project.

- ✓ Initial investment, maintenance cost, energy cost (over the life of the project) monitoring and training cost, are – and should be - included in the overall cost of the project.
- ✓ The energy and cost savings produced by the project need to be sufficient to cover all project costs over the term of the contract.
- ✓ EPC project contracts, typically, span a period of 10years or more.

Some of the benefits associated with the EPC and ESCO approach for implementation Energy Programs and Strategies are as follows:

- ❑ EPC's save company capital for projects that lack financial justification.
- ❑ EPC's fund energy conservation projects from savings generated by the project.
- ❑ EPC's reduce repair and maintenance costs caused by inadequate, aging, or obsolete equipment, electrical or non-electrical.
- ❑ EPC's, and energy conservation projects in general, provide secondary benefits i .e. increased employee productivity, safe and more comfortable working environment. For example, energy efficient lighting projects/programs, computer/PLC based automated HVAC systems and computer/PLC based EMS, Energy Management Systems.
- ❑ Improve the environment and conserve energy resources.

Electrical Energy Related Measures Typically Included in ESCO or EPC Endeavors

Additional details on some of the mainstream technical measures, typically included in ESCO or EPC driven projects, are recounted for reference below:

- **Lighting:** Replacement of inefficient lighting systems with energy efficient lamps, energy efficient ballasts and optimally designed light fixtures. Examples of such measures include:
 - Replacement of mercury lamps with higher efficacy sodium vapor lamps
 - Replacement of incandescent and, in some cases, florescent lamps with high efficacy LED, Light Emitting Diode, lamps. An LED is constructed similar to a regular diode with the exception of the fact that when an LED is forward biased, holes and the electrons combine at the p-n junction releasing light energy, or photons. Symbol for a light emitting diode is shown below:

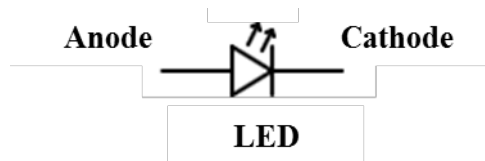

- Replacement of older florescent lamps and fixtures with high efficiency T-8 or T-5 florescent light systems.
 - Replacement of lighting systems, that are inadequately designed by today's standards, with light systems that are designed with emphasis on important factors such as lighting efficacy (lumens/watt), CU, coefficient of utilization (Lumens Reaching the Work Plane/Total Lumens Generated). See Segment 4.
- **HVAC, Heating, air conditioning and ventilation:** Optimization and improvement of chilled water systems, replacement of lower efficiency and high maintenance HVAC Systems with HVAC systems that carry high Energy Star Rating, utilize high efficiency chillers, use green technologies, i.e. geothermal, solar, thermal storage, etc. Convert manual

HVAC control systems to BMCS, Building Management Control Systems, or Direct Digital Control Systems¹.

- **Control Systems:** Control systems incorporating effectively designed and optimally applied control architecture in energy usage and energy generating systems. These control systems employ cutting edge - yet proven - sensors, transducers and other control devices for field application. Furthermore, these control systems are driven by CPUs, Central Processing Units, or computers and PLCs, Programmable Logic Controllers that offer the latest improvements in hardware, firmware, application software and HMI, Human Machine Interface, options.
- **Building Envelope Improvements:** Measures in this category include infrastructure improvements related to the building envelope or exterior.
- **Cogeneration and CHP:** Cogeneration and CHP, Combined Heat and Power, measures address the *supply side* of the energy equation, through production of electricity while catering to other needs such as steam required for production processes. Measures in this category can include the following:
 - **Topping Cycle Cogeneration System:** In topping cycle cogenerating systems, electrical power is generated at the top, or beginning, of the cogeneration cycle.
 - **Bottoming Cycle Cogeneration System:** In bottoming cycle cogenerating systems, electrical power is generated at the bottom, or tail end, of the cogeneration cycle.
 - **Combined Cycle Cogeneration System:** In the combined cycle cogenerating systems, electrical power is generated at the top *and* bottom segment of the cogeneration cycle.

Since the combined cycle systems employ both the topping cycle feature as well as the bottoming cycle feature, they offer higher efficiency in the production of electricity.

¹ Thermodynamics Made Simple for Energy Engineers, by S. Bobby Rauf

- **Demand Response Measures:** Demand response measures are projects or actions undertaken to avert the need for *electrical power generating*

Demand response measures are also referred to as DSM, or Demand Side Management, measures. DSM is an important tool to help balance supply and demand in electricity markets, to reduce price volatility, to increase system reliability and security. This enables the utility industry to rationalize investment in electricity supply infrastructure and to reduce greenhouse gas emissions. Examples of these measures include the following:

- Energy efficiency enhancement technologies, management practices or other strategies in residential, commercial, institutional or governmental arena that reduce electricity consumption.
- Demand response or load management technologies, management practices or other strategies in residential, commercial, industrial, institutional and governmental arena that shift electric load from periods of peak demand to periods of off-peak demand, including pump storage technologies.
- Industrial by-product technologies consisting of the use of a by-product from an industrial process, including the reuse of energy from exhaust gases, steam or other manufacturing by-products that are used in the direct production of electricity.

Figure 3.1 is Quantity (Q) – Price (P) graph. This graph shows the effect of *demand response* on *demand elasticity*. The inelastic demand in the electrical power market place is represented by curve **D1**. The high price **P1** associated with the *inelastic* demand **D1** is extrapolated off the point of intersection of the supply curve **S** and the demand curve **D1**. When demand response measures are introduced, demand becomes *elastic*. The elastic demand is represented by curve **D2**. The point of intersection of elastic demand curve **D2** and the supply curve **S** precipitates in a substantially *reduced market price P2*.

It is estimated that a 5% lowering of the demand would result in a 50% reduction in price during peak hours, as demonstrated in the California Electricity Crisis of 2000-2001¹.

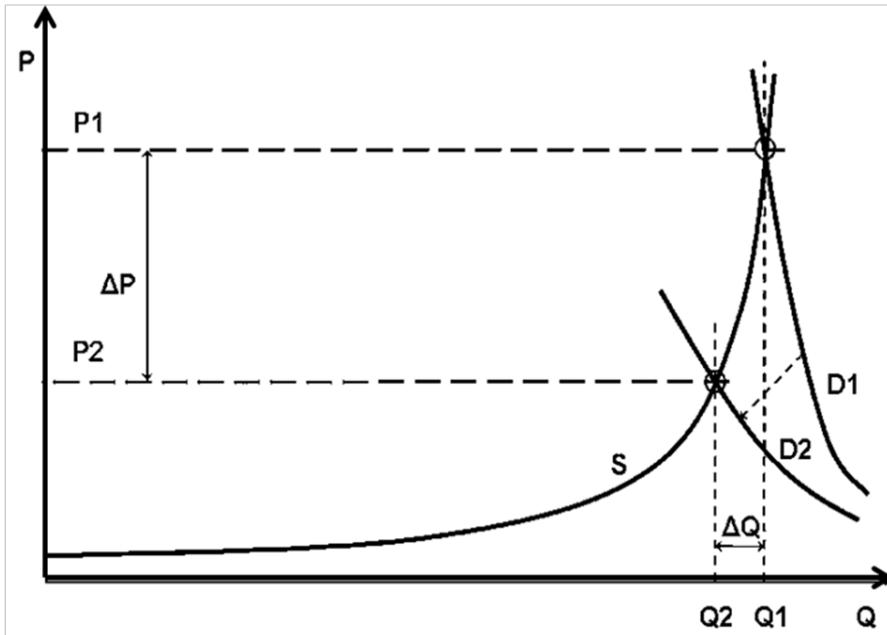

Figure 3.1. Demand elasticity and the effect of demand response.

Other studies, such as the two studies sponsored by Carnegie Mellon in 2006², examined the impact of demand response measures on demand elasticity and price.

Kathleen Spees and Lester Lave. CEIC-07-02 "Impacts of Responsive Load in PJM: Load Shifting and Real Time Pricing" Kathleen Spees and Lester Lave. The price reduction can be explained by the fact that operators generally plan to use the least expensive, or lowest marginal cost, generating capacity first, and use additional capacity from more expensive plants as demand increases.

¹ The Power to Choose - Enhancing Demand Response in Liberalised Electricity Markets Findings of IEA Demand Response Project, Presentation 2003.

² CEIC-07-01 "Demand Response and Electricity Market Efficiency,"

- **Renewable Energy Measures:** Renewable energy is, mostly, derived from natural resources such as sunlight, wind, rain, tides, and geothermal heat; these are energy sources, or forms of energy, that are renewable and replenished naturally. Of course, the energy harnessed from these renewable natural sources is often in form of *electrical energy*.

Some of the more proven renewable energy technologies are as follows:

- **Hydroelectric Power**
- **Biomass Energy**
 - Biomass Heat
 - Biomass Power
- **Solar Energy**
 - Solar Heat Energy
 - Solar Photo-Voltaic Electrical Energy
- **Wind Energy**
- **Geothermal Energy**
 - Geothermal Heat
 - Geothermal Power
- **Ocean or Tidal Energy**

Published data shows that approximately 13% of the total US electrical energy is derived from renewable sources. This 13% of the overall electricity generated in the US can be segmented as shown in Figure 3.3. This segmentation shows that:

- Almost 80 GW, Gigawatts, of renewable electrical energy is derived from *conventional hydroelectric dams*.
- Almost 40 GW, Gigawatts, of renewable electrical energy is derived from *wind turbines*.

Sources of U.S. Electricity Generation, 2011

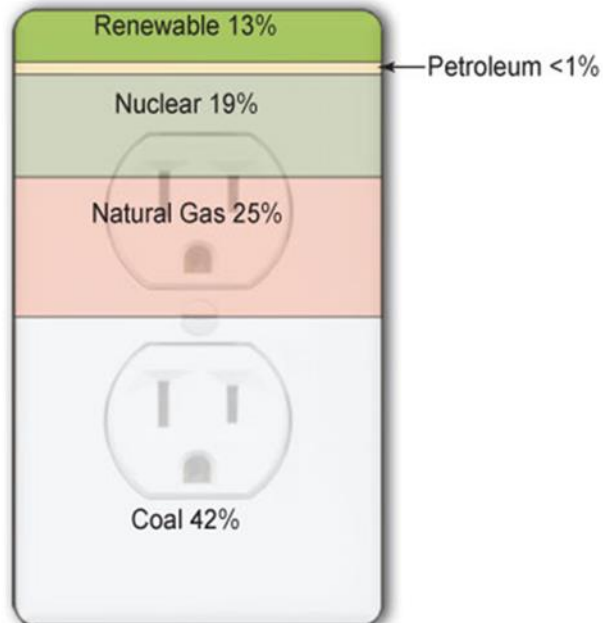

Source: U.S. Energy Information Administration, *Electric Power Monthly* (March 2012).

Figure 3.2: Sources of U.S. Electricity Generation. By EIA, U.S. Energy Information Administration

- **Solar** comes in 3rd, at almost 10 GW
- The rest of renewable electrical energy is derived from **biomass and geothermal sources**.

Renewable electricity net summer capacity for 2010

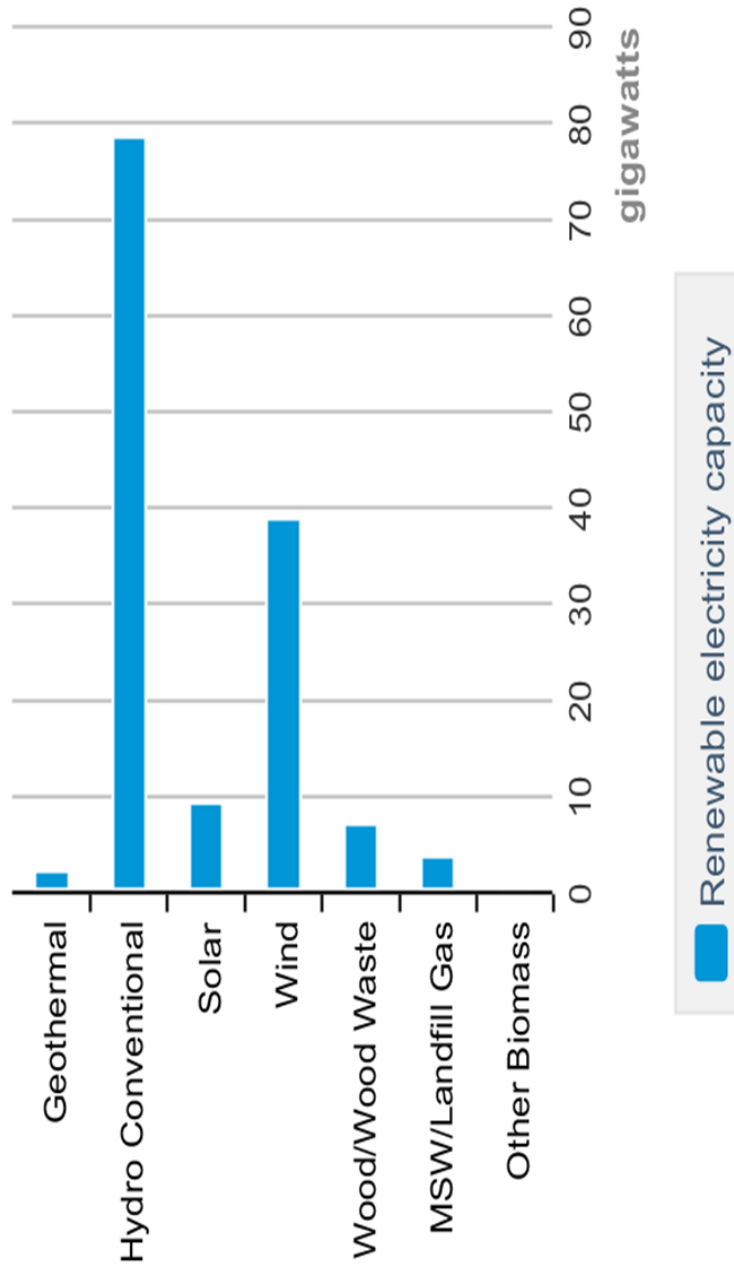

Figure 3.3: Renewable electricity generation breakdown – U.S.

- **Water and Sewer:** Consumption of water and discharge into sewage systems, at face value, may not appear to have a direct relationship with the electrical energy. However, as one examines the process behind the reclamation and distribution of potable water, the vital and indispensable role that energy plays becomes palpable. It takes energy, and therefore dollars, to drive the pumps to collect untreated water. The filtration and sanitization phases of water purification require hydraulic head to move water, which amounts to conversion of electrical energy to hydraulic head. In addition, significant and continuous amount of electrical energy is needed to store and pump water to consumers at a standard head. Hence, it's obvious that if the consumption of water is reduced, energy is conserved and the demand for electrical energy abates.

- **Sustainable Materials and Associated Operations:** Mining, transportation, refinement, treatment, sizing, packaging, marketing, sale, distribution and application of all types of materials – pure metals, alloys, non-metallic substances, polymers and myriad synthetic substances - require energy in all phases of production. Even recycling of materials, as “green” as it is, requires energy. As we assume this perspective, it becomes easy to see how conservation in the use of materials can have an impact on energy demand.

Self-assessment Problems and Questions – Segment 3

1. HP, or hourly pricing, program is a standard feature in all OPT, or Time of Use, schedules.

- A. True
- B. False

2. The energy charge rate structure with Electrical OPT schedule is:

- A. Flat, year round
- B. Tiered
- C. Exponential
- D. Is a function of time and season.

3. A large industrial electricity consumer set the peak demand in July's billing month at 40 megawatt. The demand rate structure is same as that included in Duke Energy ® OPT-I, Time of Use, rate schedule, as shown in Table 3.2. Determine the demand cost for the month.

- A. \$367,000
- B. \$505,000
- C. \$407,000
- D. \$476,579

4. Calculate the **energy charge** for the month of July considered in Problem 3 if all of the energy is consumed during On-Peak hours, for 10 hours per day. Assume that there are 30 days in the billing month and that the load factor is 1, or 100%.

- A. \$902,000
- B. \$416,808
- C. \$2,064,187
- D. None of the above

5. Which of the following statements describes the role of EPC and ESCO most accurately?

- A. The terms EPC and ESCO are synonymous
- B. EPC is method for implementing energy projects and ESCO's are entities that offer this alternative.
- C. EPC is required by Department of Energy, ESCO's are not.
- D. None of the above

Segment 4

Illumination and Lighting System Design

Introduction

Electricity is the lifeline of most non-solar, artificial, light produced and used by mankind. Substantial portion of electricity consumed in the world can be attributed to the generation of light. Most electrical energy conservation programs include lighting improvement as a cornerstone of the overall, comprehensive energy conservation effort. This is, especially, true when a program is evaluated with consideration to the ROI, Return over Investment, payback period and NPV, Net Present Value Analysis¹. Many large energy productivity improvement project portfolios depend on short payback, high ROI and high NPV lighting improvement measures to “float” the more capital intensive measures like energy efficient chillers and energy efficient air compressors. Therefore, understanding of illumination and efficacies of various lighting systems is an important and integral part of electrical engineering.

In this segment, we will examine fundamental concepts of illumination. We will gain familiarization with illumination and lighting principles, and we will learn basic considerations pertaining to lighting system design.

In the interest of facilitating continuous learning and updating of reader’s knowledge on the subject of lighting, it should be noted that IESNA, Illumination Engineering Society of North America, provides a vital leadership role in the illumination arena. IESNA is a non-profit organization

that develops and publishes lighting standards. IESNA also collaborates with ICI, International Commission on Illumination to promote uniformity of illumination standards worldwide. The reader is encouraged to stay abreast of IESNA publications to stay current on the evolving illumination standards.

¹ Finance and accounting for energy engineers, by S. Bobby Rauf.

Lighting Terms, Concepts and Standards

Solid angle: A solid angle is an angle represented by a given area on the surface of a sphere. It can also be defined as a two-dimensional angle subtended, at a point, by an object, in three dimensional space. Solid angle is denoted by symbol ω . The units for solid angle are steradians, **sr**.

Luminous flux: Luminous flux is a measure of the amount of light that passes through a certain area of cross-section ΔA . The symbol used to denote luminous flux is Φ . The units for luminous flux are **lumens**. One lumen is defined as the amount of luminous flux produced by a light source when it emits **one candela** of luminous intensity over a solid angle of **one steradian**.

A lumen is an **SI** unit. As apparent from Table 4.1, luminous flux can also be measured in watts per steradian, or **w/sr**; which implies that luminous intensity can be quantified in watts.

The formula for Luminous Flux Φ is:

$$\Phi = 4.\pi.I \quad \text{Eq. 4.1}$$

Where,

I = Luminous intensity from a uniformly radiating point source

Φ_t = Total luminous flux originating from the source

4π = Solid angle in steradians

Luminous intensity: Luminous intensity is a measure of the source intensity as seen by the eye. The symbol used to denote luminous flux is **I**. If light is perceived as emanating out, three dimensionally, from a point source, luminous intensity could be conceived as flow of the light radiation on per unit solid angle basis.

The formula for luminous intensity is as follows:

$$I = \frac{d\Phi}{d\omega}$$

$$I = \frac{\Phi}{\omega} = \frac{\Phi}{\frac{A}{r^2}} = \frac{\Phi_t r^2}{4\pi r^2} = \frac{\Phi_t}{4\pi} \quad \text{Eq. 4.2}$$

Where,

I = Luminous intensity from a uniformly radiating point source

Φ = Luminous flux, in lumens

Φ_t = Total luminous flux originating from the source

ω = Solid angle in steradians (sr) = $\frac{A}{r^2}$ Eq. 4.3

A = Area illuminated, in ft²

r = Distance of the work plane from the light source, in ft

Luminous intensity is measured in **candelas**. One candela can also be defined, mathematically, as follows:

$$1 \text{ cd} = \frac{1 \text{ lm}}{\text{sr}}$$

Illuminance: Illuminance defines the *quantity* of light that falls on a given *surface area*. The area can be real area - pertaining to a real surface - or it can be a virtual area in space. Illuminance is denoted by **E**. The formula for computing illuminance is as follows:

$$E = \frac{\Phi_t}{A} = \frac{\Phi_t}{4\pi r^2} \quad \text{Eq. 4.4}$$

Where,

Φ_t = Total luminous flux originating from an omnidirectional light source

A = Spherical area illuminated by the omnidirectional light source

r = Distance the light source and the illuminated spherical area

E = Illuminance

The units for illuminance, in the SI realm are “**lux**.” The units for illuminance, in the US realm are **ft-c**, or foot candles.

One lux can be defined as:

$$1 \text{ lux} = \frac{\text{Number of lumens}}{\text{m}^2} \text{ or } \frac{\text{Lm}}{\text{m}^2}$$

One ft-c can be defined as:

$$1 \text{ ft-c} = \frac{\text{Number of lumens}}{\text{ft}^2}, \text{ or } \frac{\text{lm}}{\text{ft}^2}$$

Illuminance is also referred to as *illumination*, *brightness* or, *irradiance*, and as such, it could be quantified in terms of **Watts/m²**.

While the more common illumination entities are introduced and discussed in this segment, Table 4.1 shows symbols, units and conversion factors for many common and uncommon illumination entities.

Symbols, Units and Conversion Factors for Common Illumination Entities				
Entity/Quantity	Symbol	Metric/SI Units	Alternative Units	Explanation
Illuminance	E	lux	lm/m ²	lm (lumens)
Irradiance	E	W/m ²	-	W (Watts)
Radiometric Illuminance	E_e	W/cm ²	-	W (Watts)
Photometric Illuminance	E_v	Phot	lm/cm ²	Phot = Photons
Luminous Intensity	I	cd (candela)	Lumens/sr	sr (steradians)
Luminous Efficacy	K	lm/watt	-	Lumens/watt
Luminance	L	cd/m ²	-	Candela per unit area
Radiance	L	W/sr.m ²	-	watts/steradians/meter ²
Luminance Existence	M	lm/m ²	-	Lumens/sq. meter
Luminance Flux Density	M		lm/ft ²	Lumens/sq. foot
Luminous Flux	ϕ	cd (candela)	Watt/sr	watts/steradians
Radiant Intensity	I	cd (candela)	Watt/sr	watts/steradians
Transmittance	T	-	-	ϕ_T/ϕ_i
Radiant Energy Density	ω	J/m ³		joules/cubic meters
Luminous Efficacy	V	-	-	V = Joules/mass

Table 4.1: Symbols, units and conversion factors in illumination

Example 4.1

A two (2) lumen omnidirectional light source is located 5 meters from a 1 meter diameter target as shown in the diagram below. Determine the following illumination parameters for this scenario:

- Luminous intensity of the source.
- Luminous flux emitted by the source and received by the target
- Illuminance at the given distance of 5 meters.

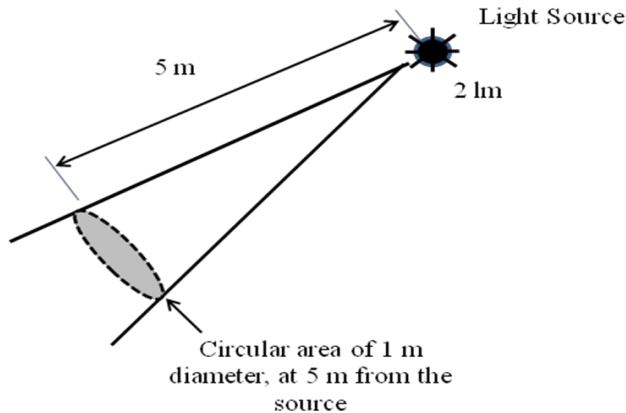

Solution

a) Luminous intensity of the source.

The formula for luminous intensity is as follows:

$$I = \frac{\Phi}{\omega}$$

And, $\omega =$ solid angle, in steradians $= \frac{A}{r^2}$

Where,

$$\begin{aligned} A &= \text{Area illuminated, in m}^2 \\ &= \pi \cdot (\text{radius of illuminated circle})^2 \\ &= \pi \cdot (1/2 \text{ m})^2 = \mathbf{0.785 \text{ m}^2} \end{aligned}$$

$r =$ Distance of the work plane from the light source = **5 m**

$I =$ Luminous intensity from a uniformly radiating point source

$\Phi =$ Luminous flux at the source, in lumens

Therefore,

$$\omega = \frac{A}{r^2} = \frac{0.785 \text{ m}^2}{5 \text{ m}^2} = 0.0314 \text{ sr}$$

And,

$$I = \frac{\Phi}{\omega} = \frac{2}{0.0314} = 63.69 \text{ lm/sr}$$

b) Luminous flux emitted by the source and received by the target

The formula for Luminous Flux Φ is:

$$\Phi = 4.\pi.I$$

Where,

I = Luminous intensity as calculated above = 63.69 lm/sr

4π = Solid angle in steradians

$$\Phi = 4.\pi \text{ sr.}(I) = 4.\pi \text{ sr.}(63.69 \text{ lm/sr}) = 800 \text{ lm}$$

c) Illuminance at the given distance of 5 meters.

$$E = \frac{\Phi_t}{A} = \frac{\Phi_t}{4\pi r^2} = \frac{2}{4.(3.14).(5\text{m})^2} = 0.0064 \text{ lm}$$

Where,

Φ_t = Total luminous flux originating from an omnidirectional light source

A = Spherical area illuminated by the omnidirectional light source

r = Distance between the light source and the illuminated spherical area

Luminous Efficacy or Luminous Efficiency

Luminous efficacy is also referred to as luminous efficiency or lamp efficacy. Luminous efficacy is defined as the ratio of luminous flux of a light source to the amount of power required by the light source. Since the units for luminous flux are lumens and the electrical power is measured in watts, the units for luminous efficacy are lm/W. Luminous efficacy or efficiency is denoted by the symbols “ η ” or “ K ,” and is defined, mathematically, as:

$$\eta = K = \frac{\Phi}{P}$$

Where,

Φ = Flux, in lumens

P = Electrical power demanded by the light source or lamp

Luminous efficacy is used extensively to compare energy productivity¹ of various light sources. Luminous efficacies of some common light sources or lamps are listed in Table 4.2.

The significance of luminous efficacy and its role in the design of lighting systems is illustrated through Example 4.2

Source	Power	Efficacy
	Watts	lm/W
High Pressure Sodium Vapor Lamp	400/1000	125/130
Low Pressure Sodium Vapor Lamp	180	180.00
Mercury Fluorescent Lamp	400	58.00
Mercury free Fluorescent Lamp	40	80.00
Mercury Vapor Lamp	100/1000	36/65
Metal Halide	400/1000	85/100
Tungsten Lamp (Incandescent)	25/100/1000	10/16/22

Table 4.2: Efficacy Values for Common Light Sources

¹Finance and Accounting for Energy Engineers, by S. Bobby Rauf

Example 4.2:

A 40 watt fluorescent lamp, with a rated luminous efficiency factor (**K**) of 80 lm/W, is mounted to the ceiling of an office as shown in the diagram below. The purpose of this light fixture is to provide adequate lighting for work being performed on the desk. Assuming that the interior design of the office allows the lamp to illuminate hemispherically, determine the illumination level on the desk in the office.

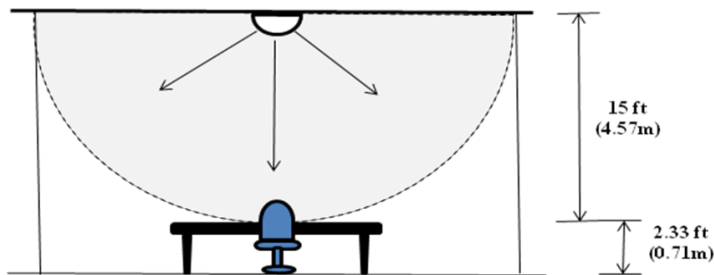

Solution:

Illumination level and illuminance, **E**, are synonymous. As stated earlier in this segment, Illumination level can be defined, mathematically, as follows:

$$E = \frac{\Phi}{A} \quad \text{Eq. 4.4}$$

Where,

Φ = Luminous flux

A = Spherical area illuminated, in ft² or m²

In this case,

$$\begin{aligned} \Phi &= \text{Luminous flux} = K \text{ (lm/W)} \cdot (\text{Power Rating of the Lamp in Watts}) \\ &= 80 \text{ (lm/W)} \cdot (40 \text{ Watts}) \\ &= 3200 \text{ lm} \end{aligned}$$

Since the area over which the light is radiated is “hemispherical” and not spherical:

$$A = \frac{1}{2} \cdot (\text{Area of a Sphere}) = \frac{1}{2} \cdot (4\pi r^2) = 2\pi r^2$$

$$E = \frac{\Phi}{2\pi r^2}$$

Where,

r = Radius of the hemisphere

= Height of the lamp from the top of the desk = 15 ft or 4.57 m

Therefore, illumination level in foot-candles (US Unit System) would be:

$$\begin{aligned} E_{ft-c} &= \frac{\Phi_{Lumens}}{2\pi r^2} = \frac{\Phi_{Lumens}}{2\pi(15\text{ft})^2} = \frac{3200\text{lm}}{2\pi(15\text{ft})^2} \\ &= 2.264 \text{ lm/ft}^2 \\ &= 2.264 \text{ ft-c} \end{aligned}$$

And, the illumination level in lux (SI Unit System) would be:

$$\begin{aligned} E_{Lux} &= \frac{\Phi_{Lumens}}{2\pi r^2} = \frac{\Phi_{Lumens}}{2\pi(4.572\text{m})^2} = \frac{3200\text{lm}}{2\pi(4.572\text{m})^2} \\ &= 24.36 \text{ lm/m}^2 \\ &= 24.36 \text{ lx} \end{aligned}$$

Example 4.3:

A special application lamp is rated 500 W. Using a photometer, the lamp's light output is measured and recorded to be 8000 lumens, at the lamp.

Determine the lamp's luminous efficacy, K.

Solution:

Given:

$$P = 500 \text{ W}$$

$$\Phi = 8000 \text{ lumens}$$

$$\begin{aligned} \eta = \text{Luminous Efficacy} = K &= \frac{\Phi}{P} = \frac{8000 \text{ lm}}{500 \text{ W}} \\ &= 16 \frac{\text{lm}}{\text{W}} \end{aligned}$$

IESNA Recommended Illumination Levels and Lighting Efficacy Comparison

IESNA, Illumination Engineering Society of North America has made numerous significant contributions as a non-profit lighting standards, guidelines and recommendations development body. Some of those contributions are as follows:

- 1) Recommended illuminance levels
- 2) Lighting design
- 3) Efficacy comparison between various lamps, or light sources

Recommended Illuminance or Illumination Level

Comprehensive illuminance guidelines for common indoor venues and specific tasks are shown in Table 4.3. These indoor venues, tasks and illuminance ranges are classified into categories A, B, C, D, E, F, G, H, and I. The range of illuminance levels, allocated to each category is stated in lux as well as fc (foot candles). The illuminance levels range from low, moderate to high.

IESNA Illuminance Categories and Values for Generic Indoor Activities			
Activity	Category	lux	fc
Public spaces with dark surroundings	A	20 - 30 - 50	2 - 3 - 5
Simple orientation for short tasks/visits	B	50 - 75 - 100	5 - 7.5 - 10
Working spaces with occasional visual tasks	C	100 - 150 - 200	10 - 15 - 20
Visual tasks involving high contrast or large size	D	200 - 300 - 500	20 - 30 - 50
Visual tasks involving medium contrast or small size	E	500 - 750 - 1000	50 - 75 - 100
Visual tasks involving low contrast or very small size	F	1000 - 1500 - 2000	100 - 150 - 200
Visual tasks involving low contrast or very small size, over a prolonged period	G	2000 - 3000 - 5000	200 - 300 - 500
Performance of very prolonged exacting visual tasks	H	5000 - 7500 - 10000	500 - 750 - 1000
Performance of very special visual tasks of extremely low contrast	I	10000 - 15000 - 20000	1000 - 1500 - 2000

Table 4.3: IESNA illumination guidelines

An illuminance level is selected for a specific activity or task based on an aggregate weighting factor derived from a combination of age of occupants, specific activity, pace or frequency, venue, level of importance, and background or surface reflectance. The weighting factors for these attributes are listed in Tables 4.4 and 4.5.

For Categories A through C			
Room & Occupant's Characteristics	Weighting Factor		
	-1	0	1
Age	Under 40	40 - 55	Over 55
Average Room Surface Reflectances	>70%	30% - 70%	<30%

Table 4.4: IESNA illumination level weighting guidelines, categories A through C.

Table 4.4 lists the weighting factors for categories A through C. If the nature of the task or activity falls within categories A through C, age of the subjects (or occupants) is used in combination with reflectance level (%) in the room to determine the aggregate weighting factor. If the aggregate weighting factor is +2, High illuminance number is selected. If the aggregate weighting factor is -2, Low illuminance number is selected. For aggregate scores of -1, 0 and +1, middle illuminance value is selected. This method for determination of recommended illuminance level based on age and reflectance factors is illustrated through Example 4.4.

Example 4.4:

The lobby of a government building is visited by individuals with a mean age of 59. The reflectance in the lobby is, approximately, 75%. These individuals sign a log and collect supplies once each day. Determine illuminance level the lobby's lighting system should be designed for.

Solution:

Based on the problem statement, this activity would be classified under **Category C** on Table 4.3, i.e. "working spaces with occasional visual tasks."

- From Table 4.4, the weighting factor associated with age 56 and over is +1.
- The weighting factor for reflectance of 70% or greater is -1.

- Therefore, the total weighting factor for this scenario would be $= +1 + (-1) = 0$.

According to Table 4.1 and the rules stated earlier, the aggregate weighting factor of “0” would point to the use of middle lux or lumen value under **Category-C**. The illuminance range in this category is 100 – 150 – 200 lux or 10 – 15 – 20 fc.

Therefore, the recommended illuminance would be **150 lux or 15 fc**.

For Categories D through I			
Room & Occupant's Characteristics	Weighting Factor		
	-1	0	+1
Age	Under 40	40-55	Over 55
Imp. of Speed & Accuracy	Not Imp.	Imp.	Critical
Reflectance of Task Background	>70%	30 - 70%	<30%

Table 4.5: IESNA illumination level weighting guidelines, categories D through I.

If the nature of a task or activity falls in categories D through I, Table 4.5 is used to assess the weighting factor. When a situation is classified in categories D through I, the age of the subjects (or occupants) is used - in combination with speed of activity, desired accuracy of the task, and reflectance level (%) - to determine the aggregate weighting factor. If the aggregate weighting factor is +2 or +3, high illuminance number is selected from Table 4.3. If the aggregate weighting factor is -2 or -3, Low illuminance number is selected. For aggregate scores of -1, 0 and +1, middle illuminance value is selected. This method for determination of recommended illuminance level based on age, nature of activity and reflectance factors is illustrated through Example 4.5.

Example 4.5:

An upscale custom watch-maker needs to assess the minimum illumination level in the final assembly room of its facility. The mean age of the craftsmen in this room is 56. The craftsmen are expected to work an average of 10 hours per day. The accuracy of the task is critical. The walls and the ceilings offer a measured reflectance 40%. Calculate the required illumination level.

Solution:

Upon examination of Table 4.3, the most suitable classification of this task would be **Category-G**, which entails “**Visual tasks involving low contrast or very small size, over a prolonged period.**”

As explained earlier, weighting factors for categories D through I are assessed in accordance with Table 4.5.

- From Table 4.5, the weighting factor associated with **age 56** and over is **+1**.
- Since **accuracy is critical** in the watch assembly task, the weighting factor for this task attribute would be **+1**, as well.
- The **reflectance** is given as **40%**, therefore, the weighting factor contribution in this category, in accordance with Table 4.5, would be **0**.
- The total weighting factor for this scenario is $= +1 + 1 + (0) = +2$.

According to the rules stated earlier, and the illuminance ranges stated in Table 4.3, the aggregate weighting factor of “+2” would point to the use of **High** lux or lumen value under category **G**. The illumination range for Category **G** is 2000 – 3000 – 5000 lux, or 200 – 300 – 500 fc. The highest illumination level in Category G is 5000 lux or 500 fc. Therefore, the recommended illuminance level in this watch assembly room is **5000 lux or 500 fc**.

When the nature of activity being conducted in a specific illuminated space is well defined but other attributes such as age, speed of activity, size of work elements, contrast and reflectance levels are not well defined and can

safely be assumed to be mid-range, the process of determining the illumination level can be simplified through the use of Table 4.6, below. This table is a simplified derivative of Table 4.3. Table 4.6 is derived from Table 4.3 by assuming that all weighting factor defining attributes are mid-range. This assumption yields total weighting factor for each category to be zero, which in turn results in selection of mid-range illumination level for each category.

IESNA Illuminance Categories and Values for Generic Indoor Activities			
Activity	Category	lux	fc
Public spaces with dark surroundings	A	30	3
Simple orientation for short tasks/visits	B	75	7.5
Working spaces with occasional visual tasks	C	150	15
Visual tasks involving high contrast or large size	D	300	30
Visual tasks involving medium contrast or small size	E	750	75
Visual tasks involving low contrast or very small size	F	1500	150
Visual tasks involving low contrast or very small size, over a prolonged period	G	3000	300
Performance of very prolonged exacting visual tasks	H	7500	750
Performance of very special visual tasks of extremely low contrast	I	15000	1500

Table 4.6: Illumination level guidelines for **important** tasks performed by **40 – 55 year old** individuals with **30 – 70% task background reflectance**.

Alternative, Rae Method

An alternative to the IESNA method is the Rae Method, named after M. S. Rae, who first introduced this approach in 1988. The Rae method results in target illumination levels comparable to the ones derived through the IESNA method.

Lambert's Law

Lambert's law, also called the *cosine law*, establishes the relationship between the illuminance on a surface, or target, the illuminance at the source, and the angle “ θ ” the inclined source radiation (light) portends with respect to the target surface's normal vector. Where, normal vector would be defined as a unit vector that is perpendicular to the target surface.

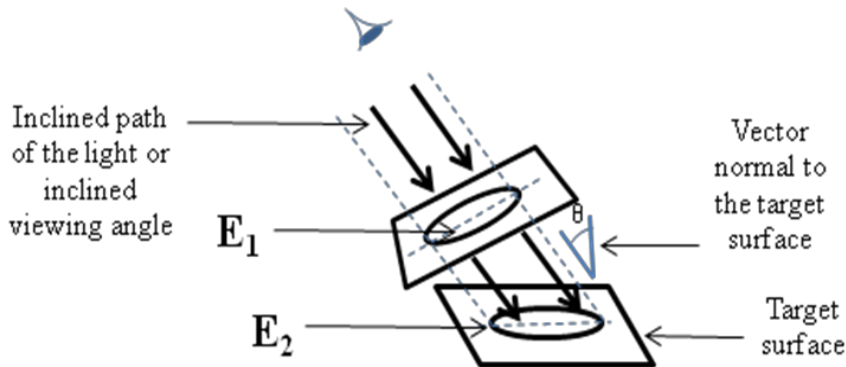

Figure 4.1: Illustration of Lambert's Law

Figure 4.1 illustrates a scenario where light travelling from a source, at a luminous level of E_1 , falls on a target area that lies at an angle θ with respect to the inclined path of the light. In such a case, Lambert's law could be interpreted to state that the illuminance on any surface varies as the cosine of the angle of incidence, θ . Therefore, Lambert's Law, can be stated, mathematically, as:

$$E_2 = E_1 \cos \theta \quad \text{Eq. 4.5}$$

Where,

E_1 = Illuminance at the source or at a specified point along the path of the light.

E_2 = Illuminance, at a point on a surface, whose normal vector portends an angle θ with respect to the inclined path of the light from the light source.

Notice that according to Lambert's Law, and **Eq. 4.5**, if the light source is directly above, perpendicular, or orthogonal to the target surface, θ , would be “0,” and

$$E_2 = E_1 \cos \theta = E_1 \cos (0) = E_1$$

Or,

$$E_2 = E_1$$

Illuminance Inverse Square Law

Within the realm of physics, inverse square law defines the relationship of extending force or radiating energy to the distance. In illumination domain, inverse square law stipulates the relationship between illuminance, illuminance intensity, and the distance. Illuminance on a surface varies in accordance with the **illuminance inverse square law**. In other words, according to the inverse square law, Illuminance is inversely proportional to the distance between the source and the surface. This law can be stated, mathematically, as follows:

$$\text{Illuminance, in lx} = E = \frac{I}{d^2} \quad \text{Eq. 4.6}$$

Where,

E = Illuminance expressed in lx, or lux

I = Illuminance intensity expressed in cd, candela

d = Distance between the luminaire and the surface being illuminated, measured in “m” or meters.

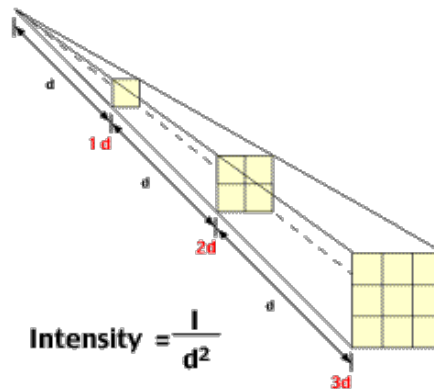

Figure 4.2: Illustration of the Inverse Square Law

The inverse square law applies only to situations where the distance **d** is at least five times the max dimension of the light source. The inverse square law can be illustrated graphically as shown in Figure 4.2. Eq. 4.7 is an extension of Eq. 4.6 and it can be used to assess the illumination contribution, by the *same* source at multiple points along the work surface.

$$E_1 r_1^2 = E_2 r_2^2 \quad \text{Eq. 4.7}$$

Where,

E_1 = Illuminance, in lx or cd, due to the source at a distance r_1 .

E_2 = Illuminance, in lx or cd, due to the source at a distance r_2 .

Example 4.6:

Consider the scenario depicted in Example 4.2 and assume that the manufacturer's specifications show tested illuminance of the lamp, at 1.0 m (3.28 ft), to be 900 lx. Determine the amount of illuminance, E , at the top of the desk surface.

Solution:

Apply the single source special case interpretation of the inverse square law in form of Eq. 4.7:

$$E_1 r_1^2 = E_2 r_2^2$$

In this case,

$$E_1 = 900 \text{ lx}$$

$$r_1 = 1.0 \text{ m}$$

$$r_2 = 4.57 \text{ m}$$

$$E_2 = ?$$

Then, by rearranging Eq. 4.7:

$$E_2 = \frac{E_1 r_1^2}{r_2^2} = \frac{(900 \text{ lx}) \cdot (1\text{m})^2}{(4.57)^2} = 43.1 \text{ lx}$$

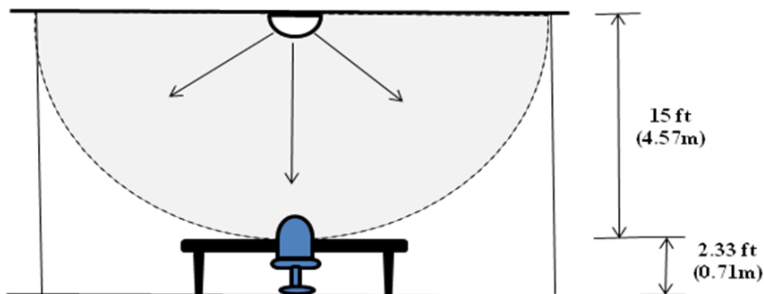

Illuminance Cosine-cubed Law:

The illuminance cosine-cubed law can be viewed as a combination of the Lambert's law and the inverse square law. As described earlier, Lambert's law, also referred to as the *cosine law*, establishes the relationship between the illuminance on a surface, or target, the illuminance at the source, and the angle “ θ ” the inclined source radiation (light) portends with respect to the target surface's normal vector. Equation 4.5 is the mathematical representation of this law. On the other hand, the inverse square stipulates the relationship between illuminance and the target distance. Mathematical representation of this inverse square law is embodied in the form of Eq. 4.6.

Combination of these laws, and their respective equations, yields **Eq. 4.8**, which is a mathematical representation of the cosine-cubed law. In order to facilitate a comparison of these laws, their respective equations are restated below.

$$E_2 = E_1 \cos\theta \quad \text{Eq. 4.5}$$

$$\text{Illuminance, in lx} = E = \frac{I}{d^2} \quad \text{Eq. 4.6}$$

Combination of Eqs. 12.5 and 12.6 yields

$$\text{Illuminance} = E = \frac{I}{d^2} \cos\theta \quad \text{Eq. 4.8}$$

When light is radiating toward a target at an angle of inclination θ , the geometry of its path can be portrayed as shown in Figure 4.3.

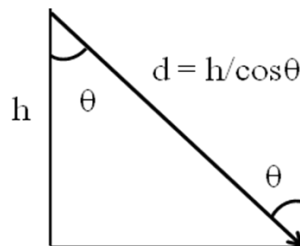

Figure 4.3: Geometry of the inclined light path

Substitution of $d = h/\cos\theta$, from Figure 4.3 into Eq. 4.8, yields Eq. 4.9, or the **cosine-cubed law**:

$$\text{Illuminance} = E = \frac{I}{h^2} \text{Cos}^3\theta \quad \text{Eq. 4.9}$$

Example 4.7:

Proposed layout of the lighting system for a work space is depicted in the figure below. The luminous intensity, I, for lamps X, Y and Z is 450 cd. Determine the following:

- a) Illuminance E_{Z-C} , at point C, due to light source Z.
- b) Illuminance E_{Z-B} , at point B, due to light source Z.

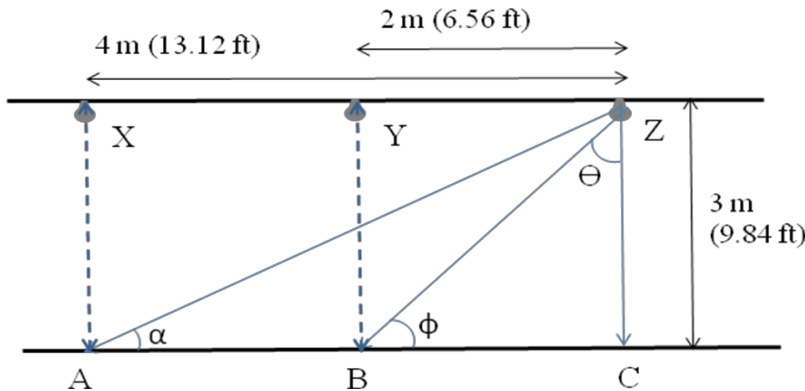

Geometry of the inclined light path

Solution:

- a) There are multiple alternative methods for solving this problem. One approach is to simply apply the cosine-cubed law. Since point C lies directly below source Z, angle $\theta = 0$. Apply Eq. 4.8:

$$\text{Illuminance} = E = \frac{I}{h^2} \text{Cos}^3\theta \quad \text{Eq. 4.9}$$

$$\begin{aligned} E_{Z-C} &= \frac{I}{h^2} \text{Cos}^3\theta = \frac{450 \text{ cd}}{3^2} \text{Cos}^3(0) \\ &= \frac{450 \text{ cd}}{(3\text{m})^2} (1) = 50 \text{ cd/m}^2 \text{ or } 50 \text{ lx} \end{aligned}$$

b) In this case, the angle of the angle of the light path under consideration is not zero. Therefore, before the law of cubed cosine can be applied, the angle θ must be determined.

Applying Pythagorean theorem to the triangle **ZBC**:

$$\theta = \text{Tan}^{-1}\left(\frac{\text{BC}}{\text{ZC}}\right) = \text{Tan}^{-1}\left(\frac{2}{3}\right) = 33.7^\circ$$

Then, by applying the cosine-cubed law, or Eq. 4.9:

$$\begin{aligned} E_{Z-B} &= \frac{I}{h^2} \text{Cos}^3\theta = \frac{450 \text{ cd}}{3^2} \text{Cos}^3(33.7^\circ) \\ &= \frac{450 \text{ cd}}{(3\text{m})^2} (0.576) = 28.8 \text{ cd/m}^2 \text{ or } 29 \text{ lx} \end{aligned}$$

Lighting Design Considerations

Lighting system design is driven primarily by the illuminance requirement at the point of interest. Factors that must be considered in lighting design are as follows:

- Type of light source
- Nature of task, or tasks, being performed
- Illuminance contributed by direct light
- Illuminance contributed by reflected light
- Illuminance contribution by delighting measures, when lumen method is used
- Interior only light when zonal cavity method is used

Daylight Based Design Considerations

As implied in the list of factors above, lighting systems design varies depending on the lighting approach employed. When daylight is included among the light sources in a lighting system, the following points must be noted:

- Daylight consists of unique spectra and light-level distributions. This distinguishes the characteristics and performance of daylight from those exhibited by artificial light sources.
- Daylight varies seasonally
- Standard power distributions of daylight, allow illuminance from the sun to be determined by factoring in the following factors:
 - Site location
 - Time of desired illumination
 - Solar position
 - Skylight
 - Ground light contributions
 - Human response factors

Daylight Factor Method

The daylight factor method is used with known illuminance distributions. These distributions include the standard three daylight illuminations. The data for calculating the illuminance is given in a tabular format. The daylight factor, DF, is a ratio of the illuminance at a point to the illuminance from the unobstructed sky. This definition of daylight factor, DF, can be stated mathematically as follows:

$$DF = \frac{E_x}{E_s} \quad \text{Eq. 4.10}$$

Where,

E_x = Illuminance at a point x

E_s = Illuminance from the unobstructed sky or another light source

Daylight factor can also be defined as the sum of sky component, externally reflected illuminance, and internally reflected illuminance. This definition of daylight factor can be stated in form of an Eq. as follows:

$$\mathbf{DF = SC + ERC + IRC} \quad \text{Eq. 4.11}$$

Where,

SC = Sky Component

ERC = Externally reflected component, in lumens, emitted by each light source

IRC = Internally reflected illuminance component.

Eq. 4.11 can be used to compute the DF value for a daylight system. The DF value thus defined can be substituted in Eq. 4.10, in conjunction with known source illuminance value E_s , to determine the estimated illuminance, E_x , at specific point x.

The Lumen Method

The lumen method accounts for total lumens projected by a luminaire, derated by the coefficient of utilization factor, CU, for a specific lighting scenario. The CU factor accounts for the following lighting system parameters:

- Efficiency of the luminaire
- Distribution of light or shape of the light distribution area
- Reflective properties of the space

$$E_i = \frac{(L_{\text{Total}}).(CU)}{A_w} \quad \text{Eq. 4.12}$$

Where,

E_i = Initial, unmitigated, illuminance in the work plane.

L_{Total} = Total illuminance emitted by the light source; based on manufacturer's specs.

A_w = Area in the work plane to be lit

CU = Coefficient of utilization; either given or computed using the zonal method described below.

As a light source ages, it experiences a loss in its luminance due to various factors, including dirt accumulation on the lamp, lens, reflector, etc.

Such degradation in the illuminance is accounted through computation of maintained illuminance, E_m as shown in Eq. 4.13.

$$\text{Maintained Illuminance} = E_M = \frac{(L_T).(CU).(LLF)}{A_W} \quad \text{Eq. 4.13}$$

Where,

L_T = Lumens (initial) emitted by the light source

CU = Coefficient of utilization

LLF = Light loss factor used to derate the initial illuminance

A_W = Area, in the work plane, to be illuminated

When a lighting system consists of multiple lamps or light sources, the maintained illuminance can be computed through Eq. 4.14, below.

$$\text{Maintained Illuminance} = E_M = \frac{(N_L).(L_{E/L}).(CU).(LLF)}{A_W} \quad \text{Eq. 4.14}$$

Where,

N_L = The number of lights or lamps

$L_{E/L}$ = Lumens emitted by each light source or lamp

CU = Coefficient of utilization for the lighting system

LLF = Light loss factor

A_W = Area, in the work plane, to be illuminated

There are various methods for determining, accessing or computing the CU values for specific lighting system scenarios. A thorough discussion of CU computation methods is beyond the scope of this text. Use of tables to identify the CU value for particular situations is illustrated through Example 4.8. This example utilizes Table 4.7.

Coefficient of Utilization (%)				
Wall Reflectance (%)	50	0	50	0
Base Reflectance (%)	90	90	80	80
Cavity Ratio				
0.2	86	82	77	72
0.6	80	73	71	63
1.0	75	62	67	55

Table 4.7: Coefficient of utilization

When using Table 4.7 for determination of CU, certain parameters are expected to be known or available. These parameters include (1) reflectance of the ceiling or floor, commonly referred to as the base reflectances, (2) the wall reflectance, and (3) cavity ratio.

Example 4.8:

Determine the CU, coefficient of utilization, for a lighting scenario where the wall reflectance is known to be 50%, the base (ceiling or floor) reflectance is estimated to be 90%, and the cavity ratio is 0.6.

Solution:

Identify the column in Table 4.7 that represents the given wall reflectance of 50% and base reflectance of 90%. Then, identify the row in the table that represents the given cavity ratio of 0.6. The CU value for this lighting scenario would be represented by the table entry that lies at the point of intersection of the identified column and row as shown below. This entry is 80%. Therefore, the CU value for this scenario would be **80%**.

Coefficient of Utilization (%)				
Wall Reflectance (%)	50	0	50	0
Base Reflectance (%)	90	90	80	80
Cavity Ratio				
0.2	86	82	77	72
0.6	80	73	71	63
1.0	75	62	67	55

Segment 4 - Self-assessment Problems and Questions

1. Consider the lighting scenario described in Example 4.1. Determine the impact on the luminous flux at the 1 m circular target if the distance increased to 10 m. See the diagram below.

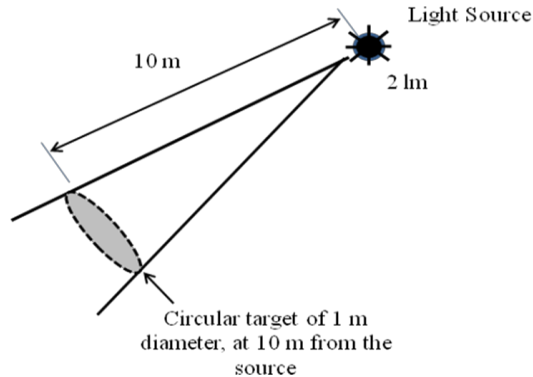

2. A 180W low pressure sodium vapor lamp is being used to illuminate an exterior space. Determine the luminous flux that would be emitted by this lamp.
3. Consider the scenario depicted in Example 4.2 and assume that the manufacturer's specifications show tested illuminance of the lamp, at 3.0 ft, to be 1000 lx. Determine the amount of illuminance, E , at the floor elevation, directly below the lamp.
4. Consider the situation stated in Example 4.7. Proposed layout of the lighting system for the work space is shown below. The luminous intensity, I , for lamp **Y** is 700 cd. The luminous intensity for lamps **X** and **Z** is 600 cd. Determine the following:
 - a) Illuminance E_{Y-B} , at point B, due to light source Y.
 - b) Total Illuminance, E_B , at point B, due to light sources X, Y and Z.

APPENDICES

Appendix A Solutions for Self-Assessment Problems

This appendix includes the solutions and answers to end of segment self-assessment problems and questions.

MADE AVAILABLE UPON PURCHASE OF COURSE

Appendix B Common Units and Unit Conversion Factors

MADE AVAILABLE UPON PURCHASE OF COURSE

Appendix C Greek Symbols Commonly Used in Electrical Engineering

MADE AVAILABLE UPON PURCHASE OF COURSE